

MESSRS. : emz-Hanauer GmbH



AGENT : _____

**SPECIFICATION
of
PYROELECTRIC PASSIVE
INFRARED SENSOR**

MODEL NO. : PSH2-323-66AA

 **NIPPON CERAMIC CO., LTD.**

176-17 Hirooka, Tottori-shi, 689-1193 JAPAN
TEL : +81-857-53-4666 FAX : +81-857-53-3532

APPROVED BY	CHECKED BY	DRAWN BY
		

MODEL NO. : PSH2-323-66AA	DRAWING NO. 1008161	REV : A	PAGE 1 / 9	August 10, 2016  NIPPON CERAMIC CO., LTD.
PART NO. :				

1. SCOPE

This specification describes a Pyroelectric Passive Infrared Sensor supplied by NIPPON CERAMIC CO.,LTD. for passive infrared sensor device.

2. TYPE of SENSOR

2.1. TYPE NAME

Pyroelectric Passive Infrared Sensor

2.2. MODEL NO.

PSH2-323-66AA

3. PHYSICAL CONFIGURATION AND DIMENSIONS

3.1. APPEARANCE

There are not remarkable wounds, spots, rust and etc.

3.2. DIMENSIONS

TO-5 Package : See Fig.1.

3.3. MARKING

Lot number and model number are marked on top surface of detector. (Figure.1)

【Lot number】

To show last one digit of the A.D. year and week of the year of a inspection completion, Nicera Identification code.

Example : 4 26 B



【Model number】

"PSH2" is marked.

4. GENERAL CHARACTERISTICS

Table.1

PARAMETER		SPECIFICATION
4.1.	Pyroelectric Passive Infrared Sensor	Balanced differential type (Series opposed type)
4.2.	Circuit Configuration	See Fig.3

MODEL NO. : PSH2-323-66AA	DRAWING NO. 1008161	REV : A	PAGE 2 / 9	August 10, 2016
PART NO. :				 NIPPON CERAMIC CO., LTD.

5. ELECTRICAL CHARACTERISTICS (ENVIRONMENT TEMPERATURE = 25 (+/-) 5 deg. C.)

Vdd = 3.3 V, unless specified.

Table.2

PARAMETER	CONDITION	SPECIFICATION
5.1. Maximum range(V)		-0.3 to 3.6 V
5.2. Supply Voltage(V)	Single Power Supply	2.7 to 3.3 V (Maximum rating : 3.6 V)
5.3. Fluctuation in Supply Voltage	Single Power Supply	Supply voltage (+/-) 3 %
5.4. Current Consumption	Vdd = 3.3V supply Circuit after Vout is not considered	Non-Detection : 20uAmax. Detection : 20uAmax.
5.5. Vout Output Voltage	Single Power Supply *)Timing Chart : See Fig.2	Non-Detection : Max. 1.0 V Detection : Min. Vdd-1.0 V
5.6. Warm-up Time	*)Timing Chart : See Fig.2	Max. 30 sec.
5.7. Setting of ON TIME	*) Setting of ON TIME : See Fig.5	Input Voltage : 0V~VddV
5.8. Setting of detection performance	*) Setting of detection performance : See Fig.6	Input Voltage : 0V~VddV
5.9. OEN Input		VoutOutput ON:0.8V~VddV VoutOutput OFF:0 ~0.2V

6. OPTICAL CHARACTERISTICS

Table.3

PARAMETER	SPECIFICATION
6.1. Field of view	X-axis : 134 deg. Y-axis : 120 deg.
6.2. Filter substrate	Silicon
6.3. Cut on (5 %T ABS)	5 (+/-) 1 micron
6.4. Transmission	≥ 70 % average 8 to 13 micron

7. ENVIROMENTAL REQUIREMENTS

Table.4

PARAMETER	SPECIFICATION
7.1. Operating Temperature	-20 to +70 deg. C
7.2. Storage Temperature	-30 to +80 deg. C
7.3. Relative Humidity	The Sensor shall operate without increase in Noise Output when exposed to 90 to 95 % RH at 30 deg. C continuously
7.4. Hermeticity	The Sensor shall be sealed to withstand a vacuum level of 21.28 kPa.

8. RoHS COMPLIANCE

This product conforms to the RoHS Directive in force at the date of issuance of this Specification Sheet.

9. REVISION

Any revision of this specification should be made in writing by discussion.

MODEL NO. : PSH2-323-66AA	DRAWING NO. 1008161	REV : A	PAGE 3 / 9	August 10, 2016
PART NO. :				 NIPON CERAMIC CO., LTD.

10. NOTES

11.1. Design restrictions/precautions

If used for outdoor applications, be sure to apply suitable supplementary optical filter, drip-proof and anti-dew construction. This sensor is designed for indoor use.

In cases where secondary accidents due to operation failure or malfunctions can be anticipated, add a fail safe function to the design.

11.2. Usage restrictions/precautions

To prevent sensor malfunctions, operational failure or any deterioration of its characteristics, do not use this sensor in the following, or similar, conditions.

- A. In rapid environmental temperature changes.
- B. In strong shock or vibration.
- C. In a place where there are obstructing materials (Glass, Fog, etc.) through which infrared rays cannot pass within detection area.
- D. In fluid, corrosive gases and sea breeze.
- E. Continual use in high humidity atmosphere.
- F. Exposed to direct sun light or headlights of automobiles.
- G. Exposed to direct wind from a heater or air conditioner.

11.3. Assembly restrictions/precautions

Soldering

- A. Use soldering irons when soldering.
- B. Avoid keeping pins of this sensor hot for a long time as excessive heat may cause deterioration of its quality. (Ex. Within 5 sec. at 350 deg.C)

Washing

- A. Be sure to wash out all flux after soldering as remainder may cause malfunctions.
- B. Use a brush when washing. Washing with an ultrasonic cleaner may cause operational failure.

11.4. Handling and storage restrictions/precautions

To prevent sensor malfunctions, operational failure, appearance damage or any deterioration of its characteristics, do not expose this sensor to the following or similar, handling and storage conditions.

- A. Vibration for a long time.
- B. Strong shock.
- C. Static electricity or strong electromagnetic waves.
- D. High or Low temperature and humidity for a long time.
- E. Corrosive gases or sea breeze.
- F. Dirty and dusty environments that may contaminate the optical lens.

11.5. Restrictions on product use

The product described in this document shall not be used or embedded to any downstream products of which manufacture, use and / or sales are prohibited under any applicable laws and regulations.

Sensor troubles resulting from misuse, inappropriate handling or storage are not the manufacturer's responsibility.

MODEL NO. : PSH2-323-66AA	DRAWING NO. 1008161	REV : A	PAGE 4 / 9	August 10, 2016
PART NO. :				 NIPON CERAMIC CO., LTD.

【F. O. V.】

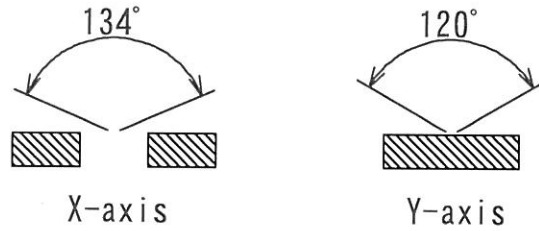

【Top View】

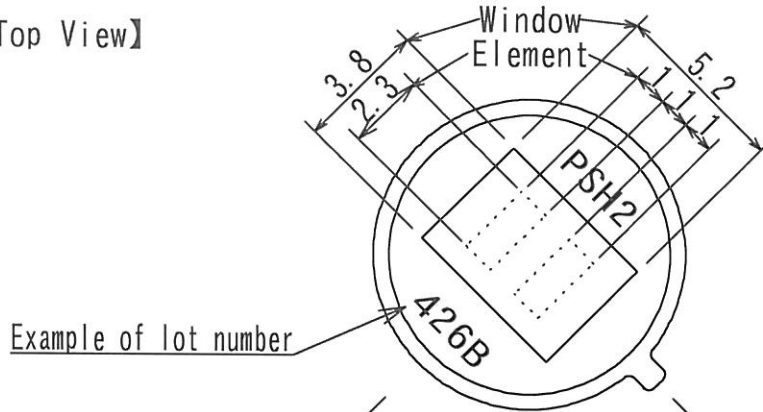

【Side View】

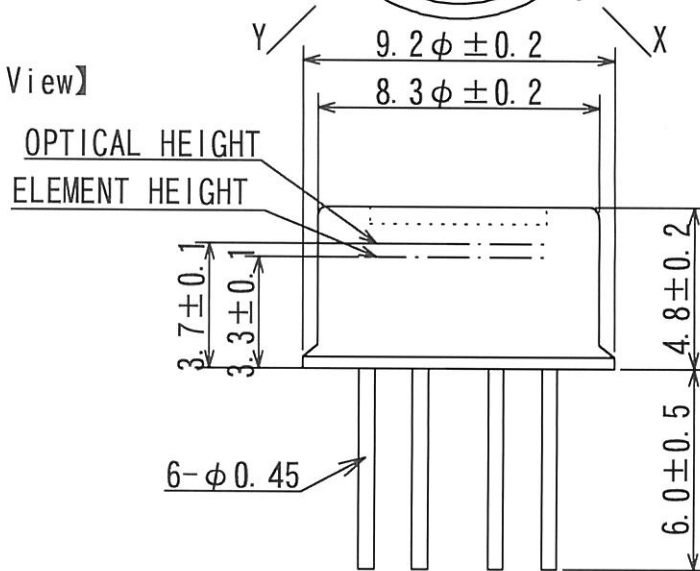

【Bottom View】

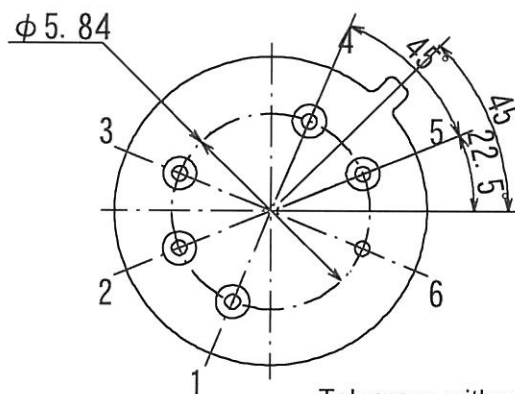

- 1 : Vdd
- 2 : Vout
- 3 : ONTIME
- 4 : SENS
- 5 : OEN
- 6 : Ground

Tolerance without instruction: (+ / -) 0.2
Unit : [mm]

(*)The sensor conforms to the standard for RoHS.

Fig.1 : Dimensions

MODEL NO. : PSH2-323-66AA	DRAWING NO. 1008161	REV : A	PAGE 5 / 9	August 10, 2016
PART NO. :				NIPPON CERAMIC CO., LTD.

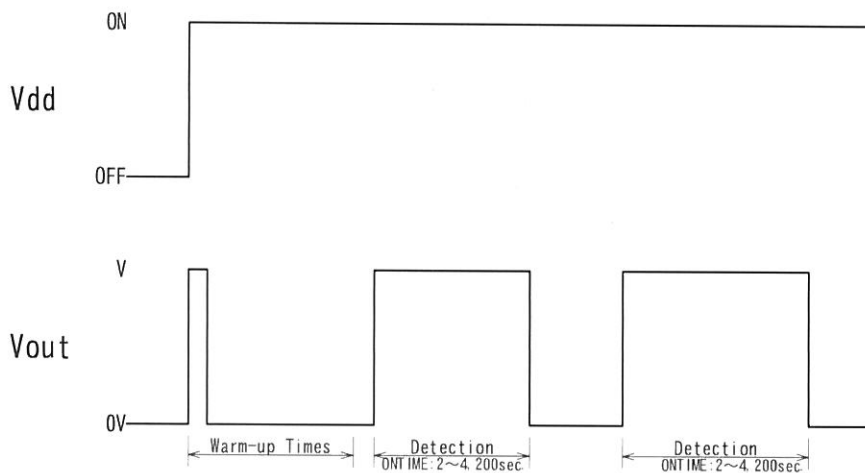

Cautions) Warm-up Time: Max. 30 sec.
 Regarding of detection or non-detection during the waiting time, ON signal may be made due to Instability of circuit

Fig.2 : Timing Chart

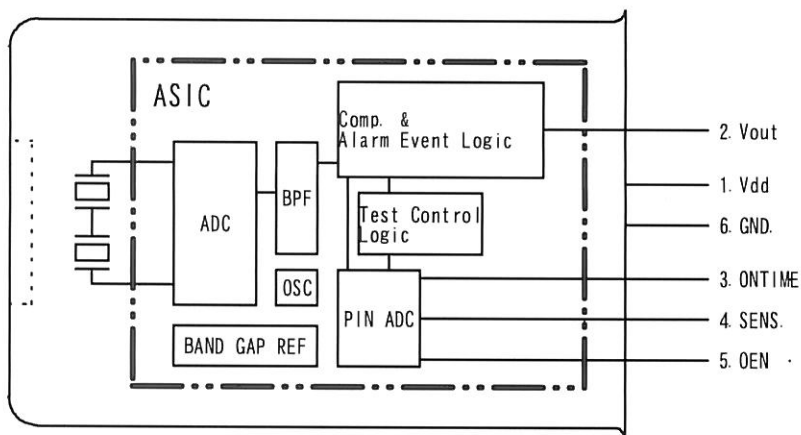

Fig.3 : Circuit Configuration

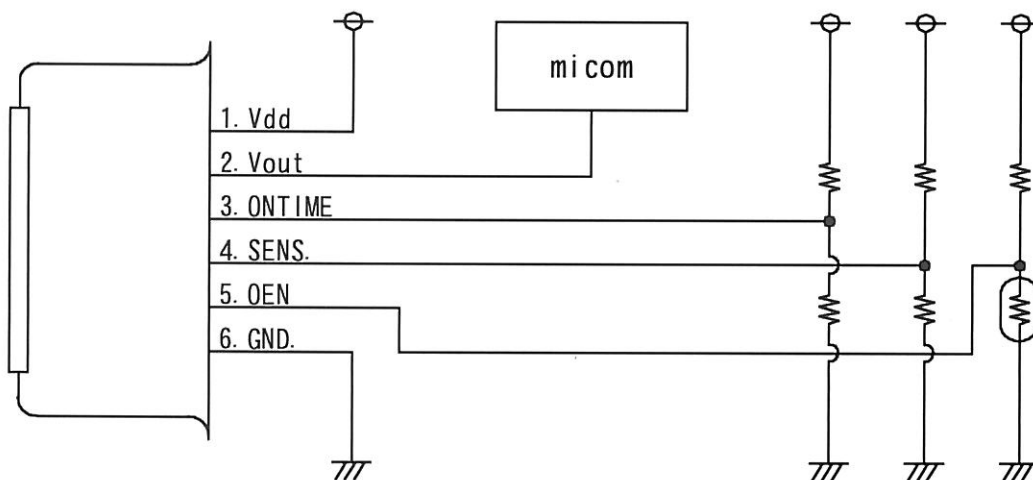

Fig.4 : Basic Application Circuit Examples

MODEL NO. : PSH2-323-66AA	DRAWING NO. 1008161	REV : A	PAGE 6 / 9	August 10, 2016
PART NO. :				NIPPON CERAMIC CO., LTD.

Pin voltage	ON Time
Vdd*1/128 or less	2 sec.
Vdd * 3 / 128	4 sec.
Vdd * 5 / 128	6 sec.
Vdd * 7 / 128	8 sec.
Vdd * 9 / 128	16 sec.
Vdd * 11 / 128	32 sec.
Vdd * 13 / 128	49 sec.
Vdd * 15 / 128	1 min. 5 sec.
Vdd * 17 / 128	2 min. 11 sec.
Vdd * 19 / 128	4 min. 22 sec.
Vdd * 21 / 128	6 min. 33 sec.
Vdd * 23 / 128	8 min. 44 sec.
Vdd * 25 / 128	17 min. 28 sec.
Vdd * 27 / 128	34 min. 57 sec.
Vdd * 29 / 128	52 min. 25 sec.
Vdd * 31 / 128 or above	1 hour 10 min.

Fig.5 : Setting of ON TIME

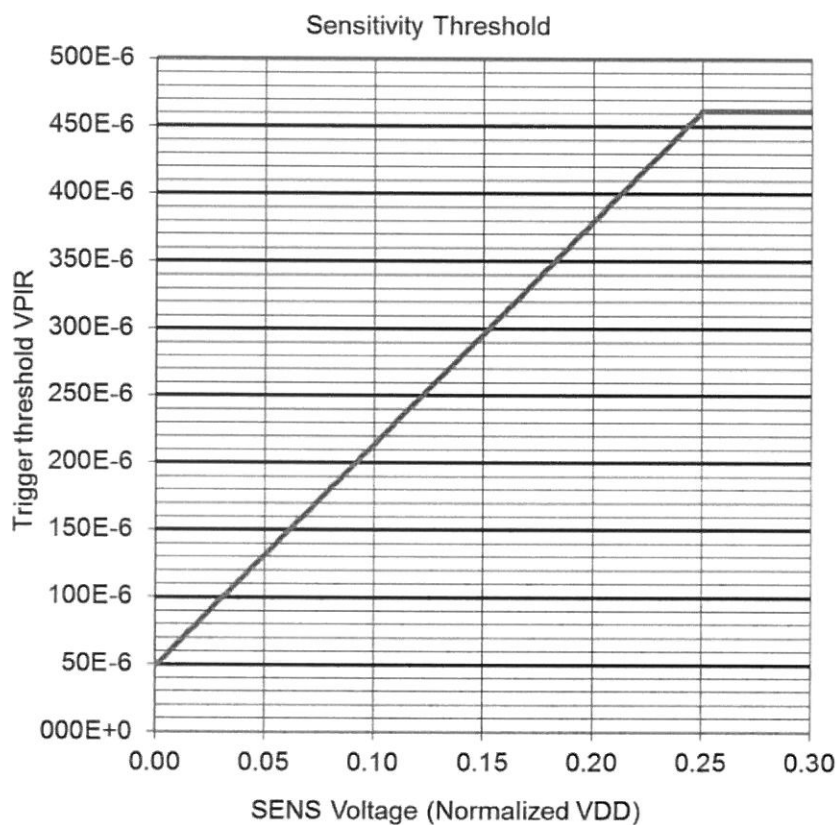



Fig.6 : Setting of detection performance

MODEL NO. : PSH2-323-66AA	DRAWING NO. 1008161	REV : A	PAGE 7 / 9	August 10, 2016
PART NO. :				 NIPPON CERAMIC CO., LTD.

Packaging specification

Refer to sketches below.

Inner package Max. 200pcs./Sheet
 Max. 400pcs./Box.

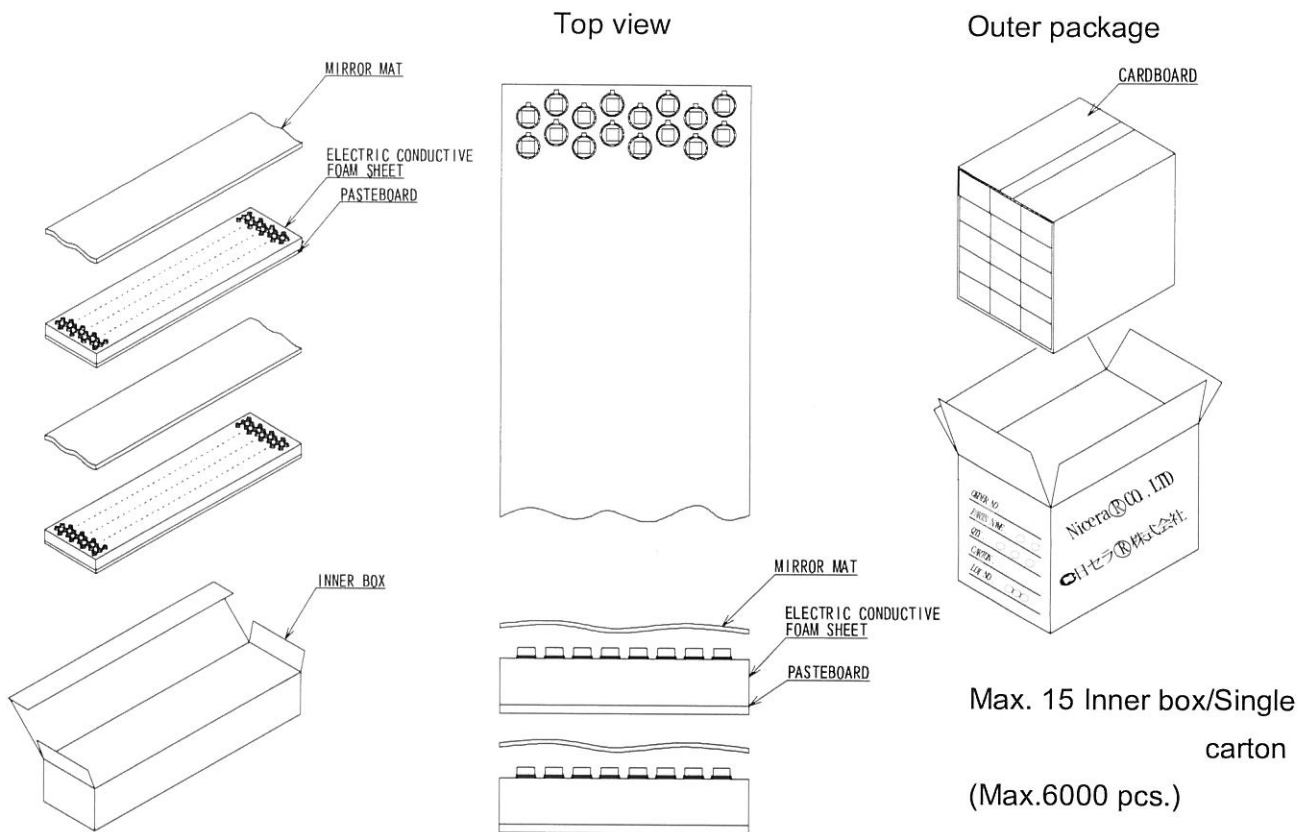

Carton

The carton is closed with sticky tape and banded by plastic tie.

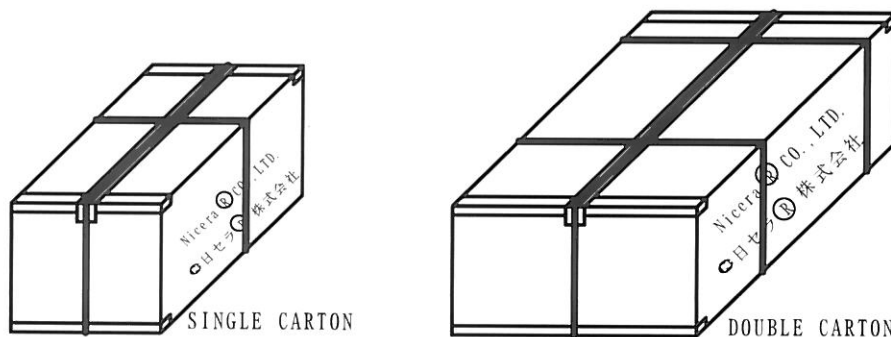

Max. 6,000 pcs./Single carton

Max.12,000 pcs./Double carton

MODEL NO. : PSH2-323-66AA	DRAWING NO. 1008161	REV : A	PAGE 8 / 9	August 10, 2016
PART NO. :				NIPPON CERAMIC CO., LTD.

Reliability Test

Test items	Test condition	Qty	Judgement conditions	Result	Judgement
1.High temperature storage test	JIS C 7021 B-10 75°C, 1000h	10	Change rate of sensor's signal output is within $\pm 20\%$ compare with the default through the sensor's output detection by NicerA's blackbody furnace.	10/10pcs. OK	○
2.Low temperature storage test	JIS C 7021 B-12 -35°C, 1000h	10		10/10pcs. OK	○
3.High humidity / temperature storage test	JIS C 7021 B-11 Condition-B 60°C, 90%RH, 1000h	10		10/10pcs. OK	○
4.Heat cycle test	JIS C 7021 A-4 -35~75°C, 30min each., 10cycles	10		10/10pcs. OK	○
5.THB (temperature/ humidity bias) Test	JIS C 7021 B-11 Condition-B 60°C, 90%RH, 5VDC, 1000h	10		10/10pcs. OK	○
6.Solder heat test	JIS C7021 A-1 ①260 °C \pm 3°C, 10 \pm 1sec. (Condition-Auto flow soldering) ②380°C \pm 10°C, 3 \pm 1sec. (Condition-Hand soldering)	5	Change rate of sensor's signal output is within $\pm 20\%$ compare with the default through the sensor's output detection by NicerA's blackbody furnace. Over 95% of solder adhere on terminal area.	5/5pcs. OK	○
7.Solderability test	JIS C7021 A-2 ①Sn-Cu,245°C \pm 2°C,3sec. ②Sn-3.0Ag-0.5Cu,245°C \pm 2°C,3sec.	5		5/5pcs. OK・Appearance OK 5/5pcs. OK・Appearance OK	○ ○
8.Electrostatic Discharge (MM method)	EIA/JESD22-A115-A C=200pF, R=0ohm, Applying 1 time	5	Confirmation of discharge voltage value (Withstand Voltage) within $\pm 10\%$ output behavior characteristic change rate n before and after voltage impression	5/5pcs. Drain:+500V, -500V 5/5pcs. Source:+500V, -500V	(Check for withstand voltage level)
9.Variable frequency vibration test	JIS C7021 A-10 Condition-A 10~55~10Hz/min., amplitude 1.5mm, X,Y,Zaxial direction/2h each.	5	Change rate of sensor's signal output is within $\pm 20\%$ compare with the default through the sensor's output detection by NicerA's blackbody furnace.	5/5pcs. OK	○
10.Drop test	JIS C 7021 A-8 Height 750mm, Board(15*15*3cm), Drop for 3times	5		5/5pcs. OK	○
11.Tensile strength test	JIS C 5402 6.26.3 Lead 19.6N for 5sec.	5		5/5pcs. OK	○

【Reliability Test Judgement Conditions】

1-1 Performance Spec

1-1-1 Signal output

Pass with under 20% change rate compare with the default.

1-1-2 Noise Output

Pass with fulfill the standard of dark-field white noise in normal temperature(25 \pm 5°C)

1-2 Structure Spec(Appearance)

No remarkable damage pollution, rust etc.

MODEL NO. : PSH2-323-66AA	DRAWING NO. 1008161	REV : A	PAGE 9 / 9	August 10, 2016
PART NO. :				 NIPON CERAMIC CO., LTD.