

DATE: _____

MESSRS. : _____

AGENT: _____

SPECIFICATION
OF
FRESNEL LENS

MODEL NO. NL-11

PART NO. _____

FRESNEL LENS MODEL NO. NL-11	PAGE 1 / 4	DRAWING NO.	REV : A
	NIPPON CERAMIC CO., LTD.		
APPROVED BY	CHECKED BY	DRAWN BY	

SCOPE

THIS SPECIFICATION DESCRIBES A FRESNEL LENS SUPPLIED BY NIPPON CERAMIC CO., LTD.

MODEL NO.

NL-11 : SPHERICAL SHAPE FRESNEL LENS

PHYSICAL CONFIGURATION

SEE FIGURE 1

MATERIAL

HIGH DENSITY POLYETHYLENE

OPTICAL CHARACTERISTICS

- 1) NUMBER OF ZONES : 17 ZONES
- 2) FIELD OF VIEW : SEE FIGURE 2
- 3) FOCAL LENGTH : 12.9 mm

ENVIRONMENTAL REQUIREMENTS

- 1) OPERATING TEMPERATURE : -20 ~ +70 °C
- 2) STORAGE TEMPERATURE : -25 ~ +75 °C

* AVOID RADIATION OF STRONG UV INCLUDED DIRECT SUNLIGHT.

MODEL NO. : NL-11 PART NO. :	PAGE 2 / 4	DRAWING NO.	REV : A
	NIPPON CERAMIC CO., LTD.		

DIMENSION

UNIT [mm]

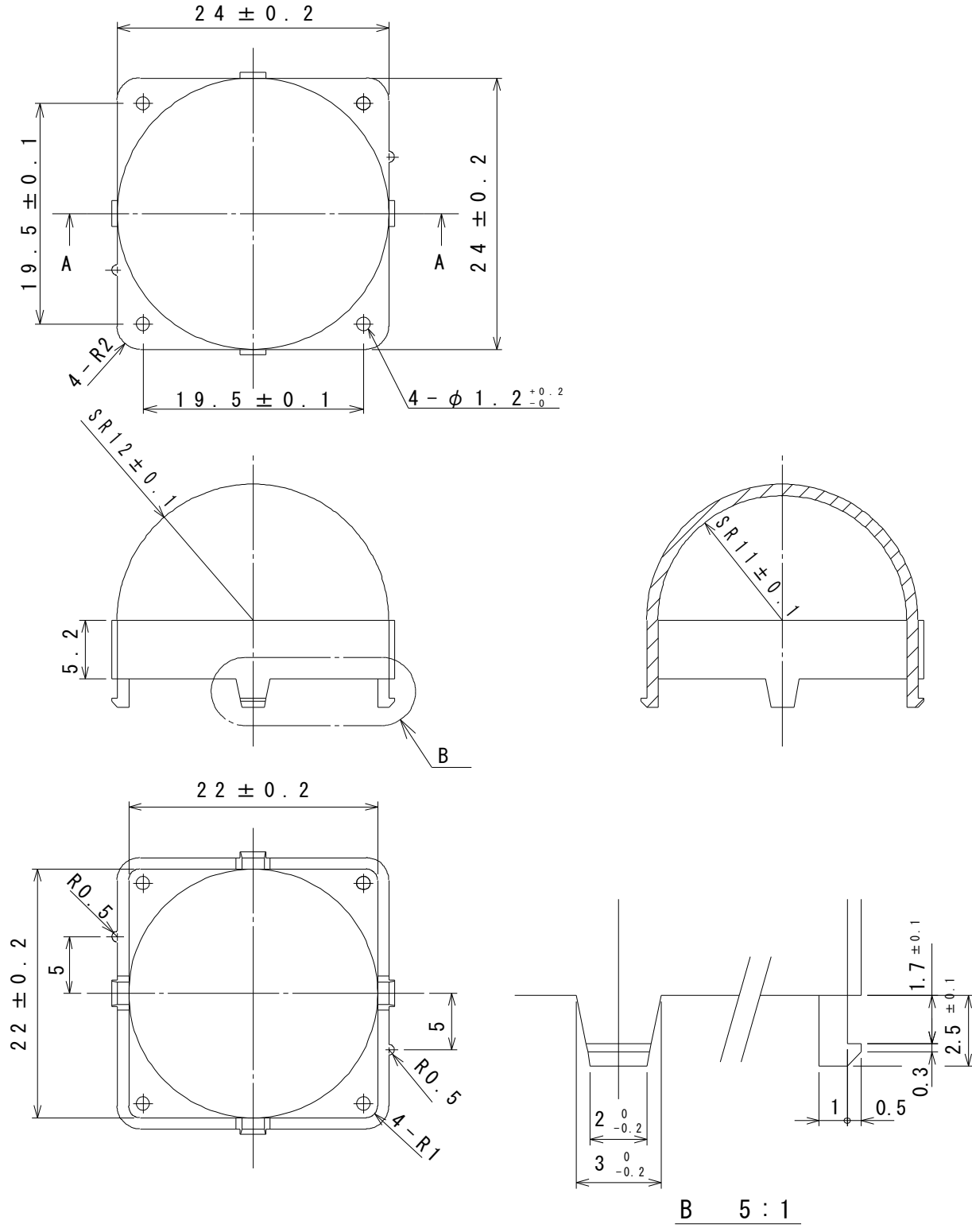

— Fig. 1 —

MODEL NO. : NL-11	PAGE	DRAWING NO.	REV :
	3 / 4		A
PART NO. :	NIPPON CERAMIC CO., LTD.		

FIELD OF VIEW

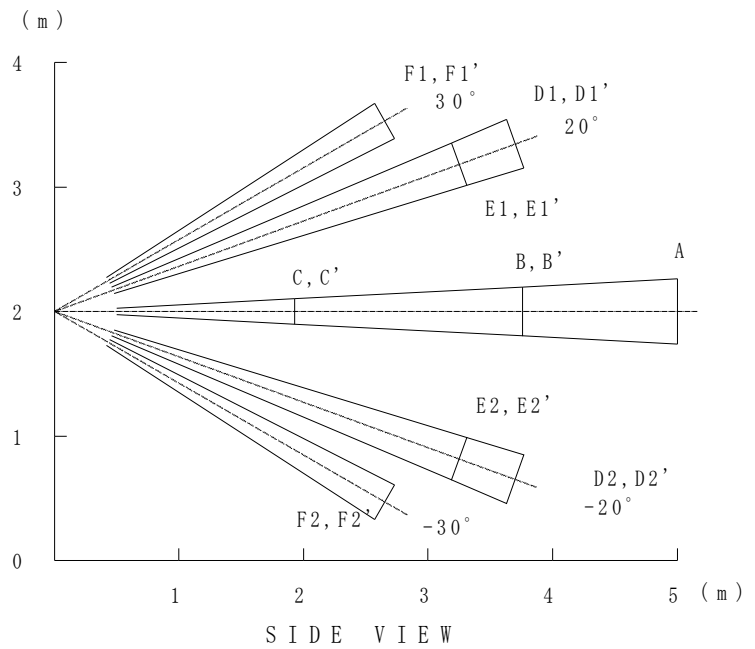
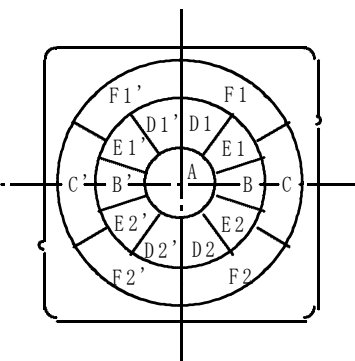
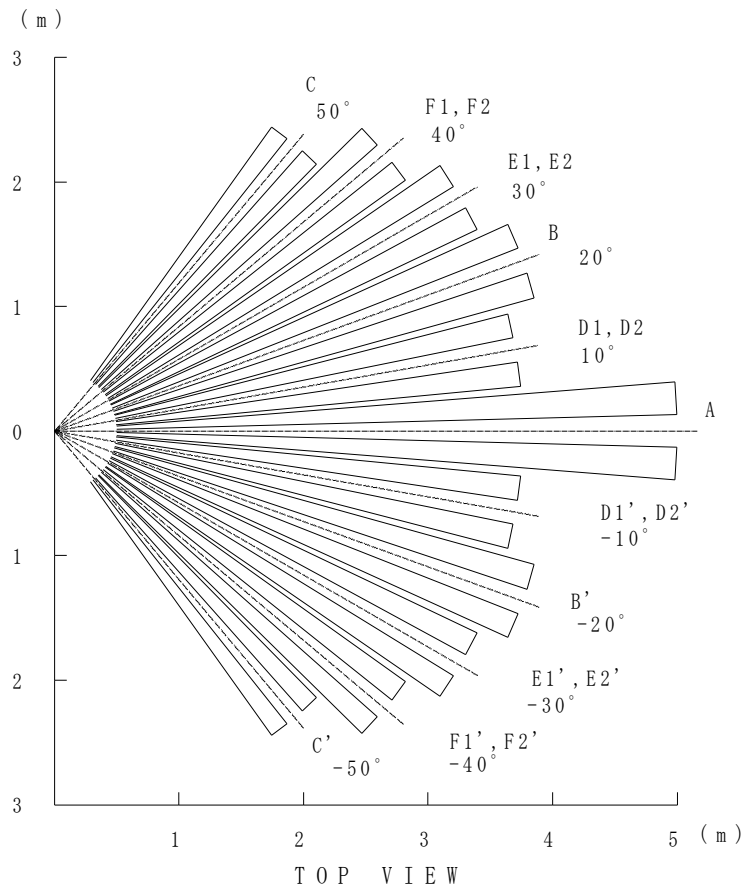
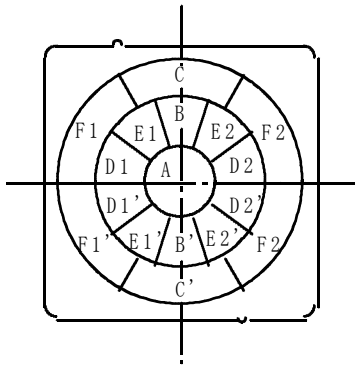

— Fig. 2 —

MODEL NO. : NL-11

PART NO. :

PAGE
4 / 4

DRAWING NO.

REV :
A

C NIPPON CERAMIC CO., LTD.