

endrich news

www.endrich.com



IN MEMORIAM

Dr. rer. nat. Mathias Würth

7. 1. 2015



We are very sorry to inform you, that the General manager of our company has unexpectedly passed away in an age of 51 years.

Dr. Würth has studied Physics in Konstanz and got there also the graduation of Dr. rer. nat. During these years he met his wife Dr. Christiane Endrich.

Dr. Würth has worked for our company 15 years together with his wife Dr. Christiane Endrich and Mrs. Ursula Endrich as managing director (CEO). Also the couple Würth/Endrich were managing directors of our daughter company Novitronic AG Switzerland. Novitronic AG is one of the most important distributors for electromechanical components in Switzerland. Dr. Würth had since the take over of this company restructured the company and integrated it in the Endrich Group.

Further more he had with an important supplier, the Japanese company Sun Electronics, founded a sales company in Germany, which is responsible for the sales of Sun Electrolytic capacitors in Europe. Because of his many trips to Japan, China, Korea and Taiwan, he met all our Asiatic cooperation partners, which supply to Endrich Bauelemente and built up a very harmonic, trustful and friendly business relation. Also he built up to many customers of Endrich close contacts and has been accepted as a competent and reliable business partner.

Dr. Würth was very open for new innovative technical novelties and products, for which the Endrich group is famous. He has developed the company as an international successful supplier, so that we export today to over 40 countries worldwide, from Asia to South America.

Because of our quality wise high class products for the automotive industry, the Endrich Group belongs now to the top 10 distributors in Europe and is a leading supplier for these market segments.

Thanks to the successful cooperation between Dr. Würth and his wife, we could increase our turn over and profitability over the years.

The total turn over of the Endrich Group of companies in Switzerland, Austria, Italy, Spain and East European countries is actually over 120 Mill. Dollar.

The Group has at the moment about 170 employees.

Dr. Würth left a big gap for all of us in the company. The Endrich group of companies will be now managed by his wife Dr. Christiane Endrich and her mother Ursula Endrich as CEOs. They will manage the company in his sense and the ideas for our future growth and success.

MOTION SENSOR NJR4265/ K-BAND INTELLIGENT DOPPLER MODULE

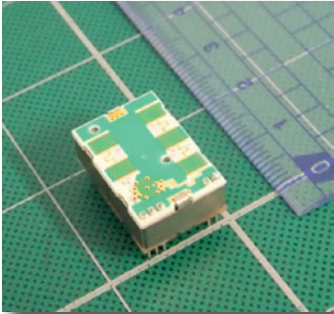

WaveEyes™

NJR4265 J1 is intelligent motion sensor that is designed for the sensing of short distance low speed movement object of pedestrian etc. The steady sensing of moving object is realized by embedded software. It is suitable for the built-in use of the sensing function to various equipments as all functions are integrated in a small package and it can easily control from PC/MCU by UART interface. Further stand alone operation is also possible.

FEATURES

- » Motion Sensor based on 24 GHz Microwave Doppler Effect Technologies
- » Antenna, RF circuit, IF amp, MCU and voltage regulator are integrated in a small package (14 × 20.4 × 8.8 mm)
- » Signal processing software for the steady sensing
- » Enhancing signal from movement object and decreasing random noises
- » Decreasing mutual interference between sensors
- » Identification of movement direction (approaching and leaving)
- » Low voltage operation and low power consumption
- » Communication with PC/MCU is available by UART interface and stand alone operation is also possible

APPLICATIONS

- » Energy saving equipment (lighting equipment, air conditioner and etc.)
- » Room access control system equipment
- » Human detection sensor for various instruments

TYPICAL RADIATION PATTERN

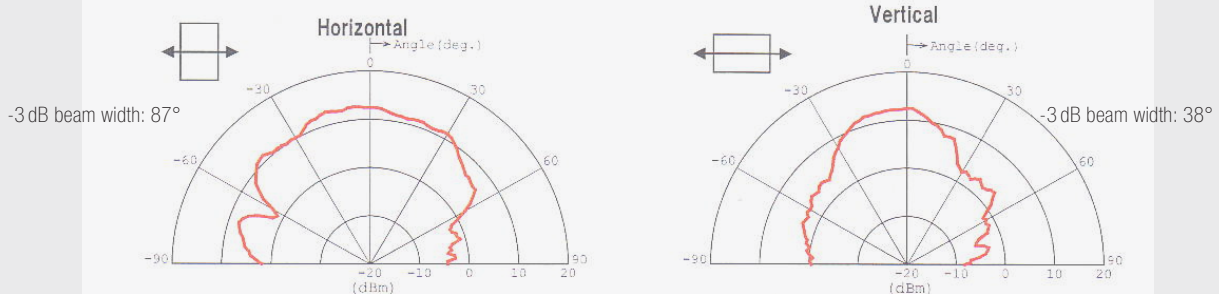

FUNCTIONAL BLOCK DIAGRAM

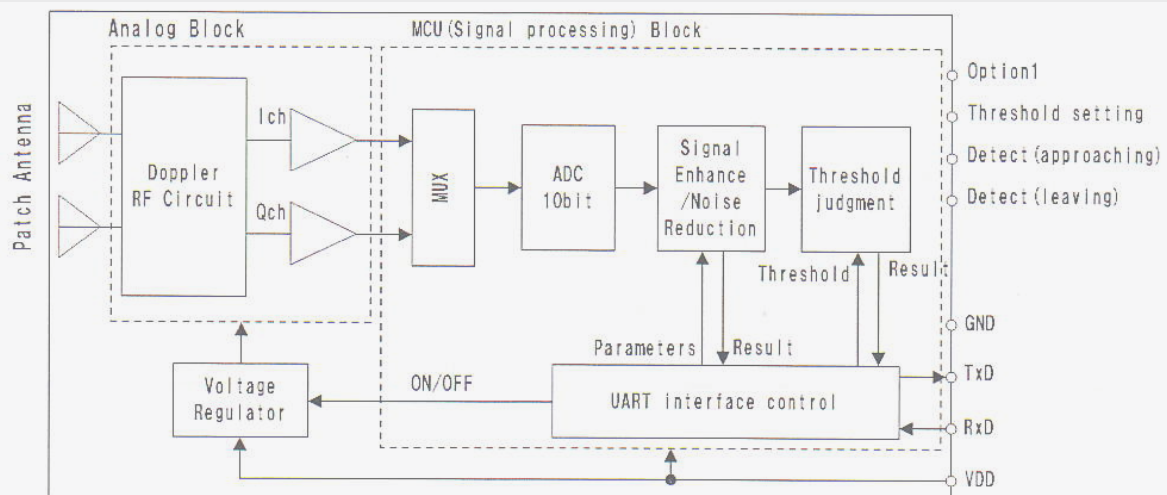

- Continued on page 8 -

AMBIENT LIGHT SENSOR NJL7302L-F3

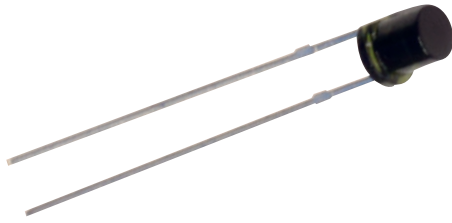

The **NJL7302L-F3** is a **phototransistor** with spectral response similar to human eyes and wide directivity.

FEATURES

- » High IR reduction
- » Lead pin package

APPLICATIONS

- » CCTV control etc.

MAXIMAL RATINGS

PARAMETER		VALUE
Collector-Emitter Voltage	V_{CE0} [V]	15
Emitter-Collector Voltage	V_{CE0} [V]	2
Power Dissipation	P_D [mW]	150
Operating Temperature	T_{OPR} [°C]	-30 ... +70
Storage Temperature	T_{STG} [°C]	-40 ... +100
Soldering Temperature	T_{SOL} [°C]	260

DIMENSIONS (mm)

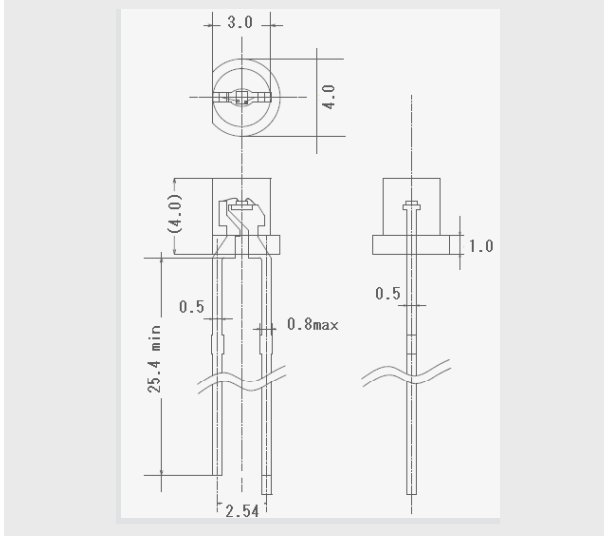

TYPICAL CHARACTERISTICS

Light Current vs. Illuminance

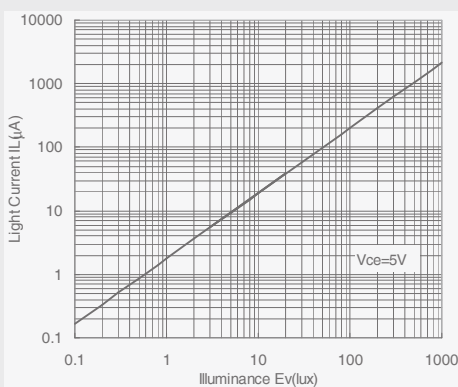

Light Current vs. Collector-Emitter Voltage

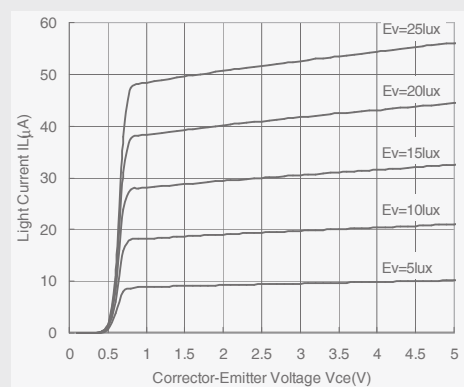

Directivity

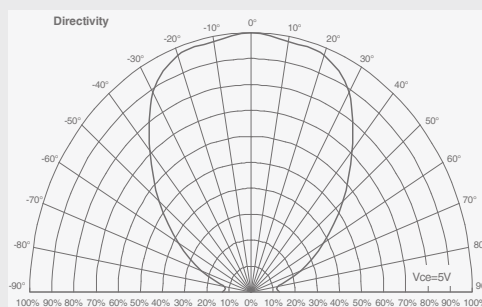

AMBIENT LIGHT SENSOR NJL7302L-F3

ELECTRO-OPTICAL CHARACTERISTICS

PARAMETER	TEST COND.	MIN.	TYP.	MAX.
Light current I_{L1} [μ A]	$V_{CE}=5V$, Light source A, 10 Lux	–	20	–
Light current I_{L2} [μ A]	$V_{CE}=5V$, white LED, 10 Lux	10	20	50
Comparison I_{L2}/I_{L1}	–	–	1	–
Dark current I_D [nA]	$V_{CE}=5V$	–	–	100
Collector-Emitter saturation voltage $V_{CE(SAT)}$ [V]	$I_L=6\mu A$, $E_v=10$ Lux	–	–	1.4
Peak wave length λ_p [nm]	–	–	550	–
Half angle $\Theta_{1/2}$ [deg.]	–	–	± 55	–
IR reduction ratio IR_re [%]	Relative sensitivity (%) @850 nm, $\lambda_p=100\%$	–	0.007	–

APPLICATION CIRCUIT (with temperature compensation circuit (TCC))

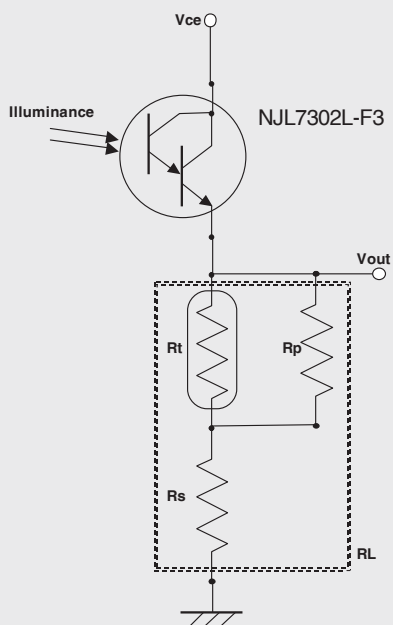

Example

Condition : $V_{ce}=5V$, $E_v=5lux$, $V_{out}=1.0V$

Rt: NTC thermistor
 Rs: Chip resistor
 Rp: Chip resistor

Rt	100k Ω
Rs	33k Ω
Rp	180k Ω

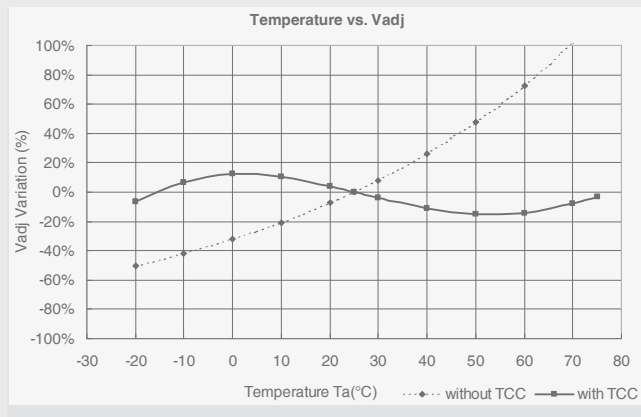

SOLOMON SUNLIGHT READABLE TFT-DISPLAYS



Solomon Goldentek Display (SGD) started up more than 20 years ago as a subsidiary of the Taiwan semiconductor group Solomon Technology Corporation. SGD specialises in extremely high-quality TFT modules in the range 3.5 to 12.1 inches which are particularly suitable for industrial applications. A further strength of SGD are sunlight readable TFT modules in the range 3.5 to 12.1 inches. The displays have a high bright backlight up to 1,500 cd/m². Furthermore, an additional Low-Reflection Polarizer can be assembled, which reduces the reflection rate significantly.

Overview of the advantages of Solomon Goldentek Display (SGD) TFT modules:

- » Modules available in high bright and super high bright versions
- » Minimum backlight lifetime of up to 50,000 hours
- » Extended operating temperature range -30°C ... +85°C
- » **5-year operational guarantee on workmanship and interface**

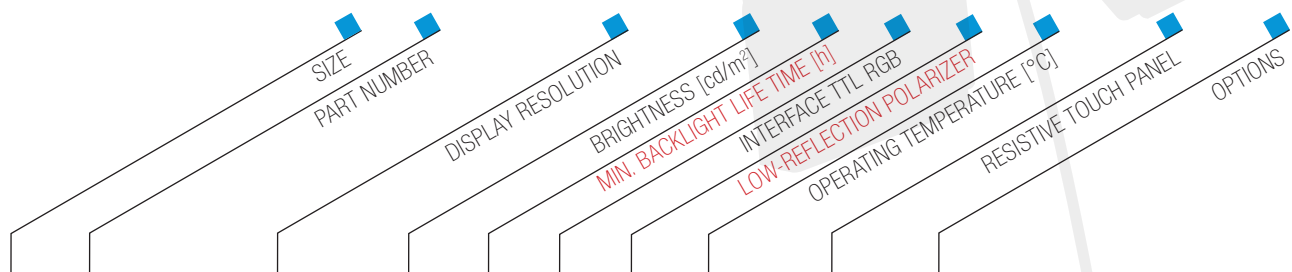

SOLOMON SUNLIGHT READABLE TFT-MODULES 3.5 "

3.5 "	GVTQ35SNAD1E0	320 × 240	800	50 k	•		-20...+70		CPU Interface, 0-Film (All-View), PCAP
3.5 "	GVTQ35SNAL1H0	320 × 240	800	50 k	•	•	-20...+70		CPU Interface, PCAP
3.5 "	GVTQ35SPAD2R0	320 × 240	640	50 k	•		-20...+70	•	CPU Interface, 0-Film (All-View)
3.5 "	GVTQ35TNAD1E0	320 × 240	800	50 k	•		-30...+85		0-Film (All-View)
3.5 "	GVTQ35TPAD2R0	320 × 240	640	50 k	•		-30...+85	•	0-Film (All-View)

SOLOMON SUNLIGHT READABLE TFT-DISPLAYS

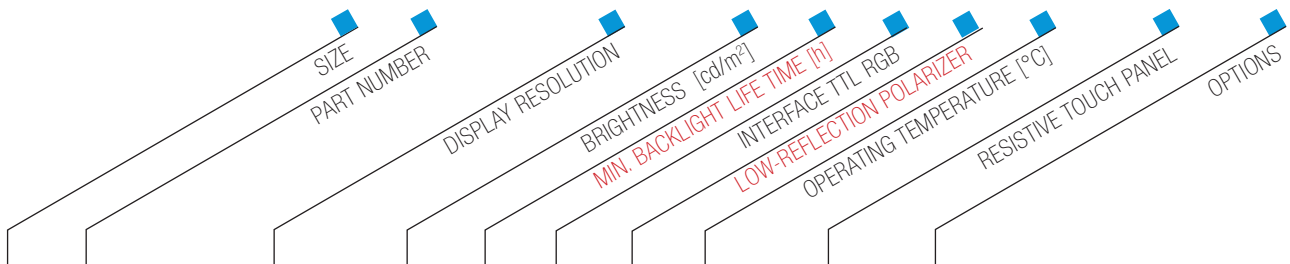

SOLOMON SUNLIGHT READABLE TFT-MODULES 4.3" to 12.1"

SIZE	PART NUMBER	DISPLAY RESOLUTION	BRIGHTNESS [cd/m ²]	MN. BACKLIGHT LIFE TIME [h]	INTERFACE TTL RGB	LOW-REFLECTION POLARIZER	OPERATING TEMPERATURE [°C]	RESISTIVE TOUCH PANEL	OPTIONS
4.3 "	GKCY43SNAH2E0	480 × 272	1000	50 k	•		-20...+70		CPU Interface, 0-Film (All-View), PCAP
4.3 "	GKCY43SNBH2H0	480 × 272	1000	50 k	•	•	-20...+70		CPU Interface, PCAP
4.3 "	GKCY43SPA1R0	480 × 272	800	50 k	•		-20...+70	•	CPU Interface, 0-Film (All-View)
4.3 "	GKCY43TNAH2E0	480 × 272	1000	50 k	•		-30...+85		0-Film (All-View)
4.3 "	GKCY43TPA1R0	480 × 272	800	50 k	•		-30...+85	•	0-Film (All-View)
5.0 "	GVTW50SNAL3E0	800 × 480	700	50 k	•		-20...+70		PCAP
5.0 "	GVTW50SPBC3R0	800 × 480	600	50 k	•		-20...+70	•	
5.7 "	GKTQ57SNAD1E0	320 × 240	1200	30 k*	•		-20...+70		0-Film (All-View), PCAP
5.7 "	GKTQ57SNAD1H0	320 × 240	1200	30 k*	•	•	-20...+70		PCAP
5.7 "	GKTQ57SPBA1R0	320 × 240	960	30 k*	•		-20...+70	•	0-Film (All-View)
5.7 "	GVTV57SNAF1E0	640 × 480	900	30 k*	•		-20...+70		LVDS Interface, 0-Film (All-View), PCAP
5.7 "	GVTV57SNAF1H0	640 × 480	900	30 k*	•	•	-20...+70		LVDS Interface, PCAP
5.7 "	GVTV57SPAF2R0	640 × 480	720	30 k*	•		-20...+70	•	LVDS Interface, 0-Film (All-View)
5.7 "	GVTV57TNAF1E0	640 × 480	900	50 k	•		-30...+80		LVDS Interface, 0-Film (All-View)
5.7 "	GVTV57TPAF2R0	640 × 480	720	50 k	•		-30...+80	•	LVDS Interface, 0-Film (All-View)
7.0 "	GVTW70SNAG1E0	800 × 480	1000	40 k	•		-20...+70		LVDS Interface, 0-Film (All-View), PCAP
7.0 "	GVTW70SRAL1H0	800 × 480	1000	40 k	•	•	-20...+70		LVDS Interface, PCAP
7.0 "	GVTW70SPA1R0	800 × 480	800	40 k	•		-20...+70	•	LVDS Interface, 0-Film (All-View)
7.0 "	GVTW70TNAG1E0	800 × 480	1000	50 k	•		-30...+85		LVDS Interface, 0-Film (All-View)
7.0 "	GVTW70TPA1R0	800 × 480	800	50 k	•		-30...+85	•	LVDS Interface, 0-Film (All-View)
8.0 "	GKNS80SNAJ1E0	800 × 600	1300	50 k	•		-20...+70		LVDS Interface
8.0 "	GKNS80SPCG1R0	800 × 600	1000	50 k	•		-20...+70	•	LVDS Interface
10.4 "	GV TSA4TNBL4E0	800 × 600	1500	50 k	LVDS		-20...+70		PCAP
10.4 "	GV TSA4TPBL5R0	800 × 600	1200	50 k	LVDS		-20...+70	•	5-wire resistives Touch Panel
12.1 "	GK VGC1MNDK2A0	1280 × 800	1300	30 k	LVDS		-20...+70		PCAP

* 50 k hours available at 1kpcs.

Specifications are subject to change without notice!

MOTION SENSOR NJR4265/ K-BAND INTELLIGENT DOPPLER MODULE

- Continued from page 3 -

ELECTRICAL CHARACTERISTICS

PARAMETER				
	MIN.	TYP.	MAX.	
Power supply	Operating voltage [V]	3.0	3.3/5.0	5.25
	Current consumption/sensing mode [mA]	-	60	-
	Current consumption/Sleep Mode [mA]	-	4	-
Sensor RF	Conformity standard	ARIB STD-T73		
	Operating frequency [GHz]	24.05	-	24.25
	Frequency stability (-20°C ... +60°C) [MHz/°C]	-1	-0.7	0
	Output power (E.I.R.P.) [dBm]	9	-	14
	2nd Harmonics [dBm]	-	-	-30
Antenna	-3dB beam width (horizontal) [°]	-	87	-
	-3dB beam width (vertical) [°]	-	38	-
	Side lobe suppression (horizontal/vertical) [dB] *	-	-	-

* no side lobes

MESUREMENT COND. OF DETECTING PERFORMANCE

- » Temperature: $T_a=25^\circ\text{C}$
- » Target of measurement: 1 adult 1.70 m, 70 kg approaching at the rate of 0.5m/s from the front of sensor
- » Installation: Sensor is installed as the antennas horizontally in a height of 1m from the ground.

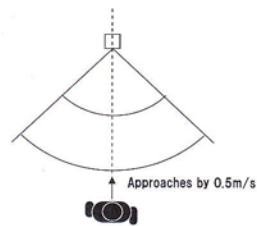
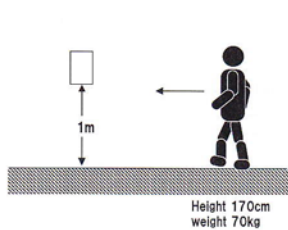

SENSING PERFORMANCE

- » Speed range of target: 0.25 ... 1 m/s
- » Max. distance in the front: 10 m
- » Detectable angle: $\pm 35^\circ$

ENVIRONMENTAL CHARACTERISTICS

- » Operating temp. range: $-20^\circ\text{C} \dots +60^\circ\text{C}$
- » Storage temp. range: $-40^\circ\text{C} \dots +80^\circ\text{C}$
- » Humidity: 0-95% @ $+30^\circ\text{C}$
- » Vibration: 49.03 m/s^2 (5 G) 30~50 Hz, 10 Min., XYZ direction
- » Shock: 196.13 m/s^2 (20 G) half sine, 11 ms, XYZ direction, 3x

new

Contact for information: Dr. Wolf · Tel. +49(0)7452-6007-23 · e-mail: t.wolf@endrich.com

HEADQUARTERS

ENDRICH Bauelemente Vertriebs GmbH · P.O.Box 1251 · D-72192 Nagold
 T +49 (0) 7452 6007-0 · F +49 (0) 7452 6007-70
endrigh@endrich.com · www.endrich.com



SALES OFFICES IN EUROPE

France:

Angers: T +33/2 41 80 33 54 · v.rousseau@endrich.com
 Paris: T +33/1 46 05 99 13 · e.cosperec@endrich.com

Austria & Slovenia

Vienna: T +43/1 66 52 52 521 · a.schwaha@endrich.com

Hungary/Bulgaria:

Budapest: T +361 / 2 97 41 91 · z.kiss@endrich.com

Switzerland – Novitronic:

Zurich: T +41/44 306 91 91 · info@novitronic.ch

Spain:

Barcelona: T +34/93 217 31 44 · spain@endrich.com