

endrich news

www.endrich.com

Our Product of the Month

MagAlpha MA300 – Angular sensor for 3-phase brushless motor

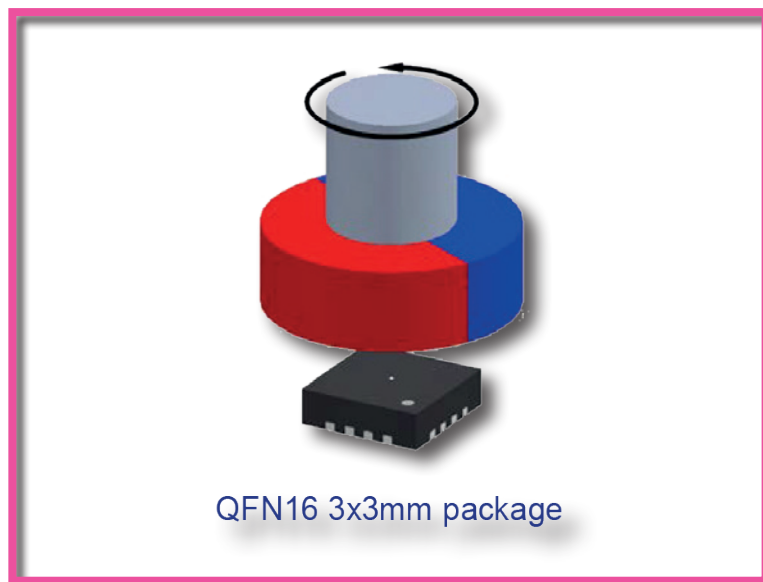

- Designed to replace the 3 Hall switch solutions for 3 phases block commutation in brushless dc motors
- The MagAlpha is an extremely fast acquisition and processing sensor, allowing accurate angle measurement at speeds from 0 to 120'000 RPM
- Commutation and Position Control with Side-Shaft Positioning Capability

 **SENSIMA**
technology sa
A Monolithic Power Systems Company

Innovative Sensor Technologies

HIGH CURRENT MOSFET RELAY (60V/2.5A/0.2Ω) – EPR311A066107EZ

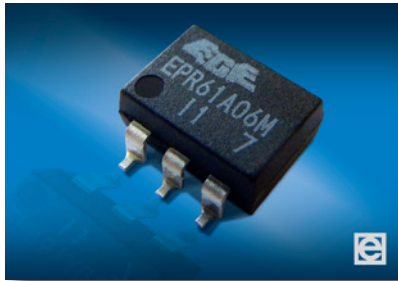

The **EPR311A066107EZ MOSFET Relay** from Excel Cell (ECE) is specifically designed for high current applications (continuous: 2.5A, peak: 4A), commonly found in industrial equipment. The MOSFET relay is a possible solid-state replacement for single-pole, normally-open (Form 1A) electromechanical relays.

The EPR311A066107EZ consists of an GaAs infrared light-emitting diode (LED) input stage optically coupled to a high-voltage output detector circuit. The detector consists of a high-speed diode array and driver circuitry to switch on/off two discrete high voltage MOSFETs. The relay turns on (contact closes) with a minimum input current of 10 mA through the input LED. The relay turns off (contact opens) with an input voltage of 1.5V or less.

A connection from PIN 4 to 6 allows the relay to switch either ac or dc loads. A connection from PIN 5 to 4, with its advantages of reduced on-resistance and higher output current, allows the relays to switch dc loads only.

The electrical and switching characteristics are specified for a temperature range of **-40°C to +85°C**.

As all MOSFET Relays the EPR311A066107EZ generates no EMI/RFI, is highly reliable, has no moving parts, offers a low On-State resistance and high isolation voltage, and is wave solderable.

The product is ideal for testing instruments, security systems, BMS (battery management systems), IoT (Internet on Things), medical equipment, IP cameras and industrial controls.

FEATURES

- » No EMI/RFI Generation
- » High reliability
- » No moving parts
- » Low drive power requirement (TTL/CMOS Compatible)
- » Low On-state Resistance
- » High isolation voltage
- » Arc-free with no snubbing circuits
- » Machine insertable or wave solderable

ELECTRICAL CHARACTERISTICS

CIRCUIT DIAGRAM		
Circuit diagram(6 PIN)	Load type	Configuration
Form A 	AC/DC	1
Form B 	DC	2
	DC	3

PARAMETER	RATING		
	min.	typ.	max.
INPUT			
Forward voltage V_F [V], $I_F=10\text{mA}$	1.0		1.5
Reverse current I_R [μA], $V_R=5\text{V}$			10
Control current I_{Fopr} [mA]	10		50
OUTPUT			
Load voltage (AC peak or DC) V_L [V], $I_0=100\mu\text{A}$	60		
Contin. rated load curr. I_L [mA], $I_F=10\text{mA}$, DIP/SMD			2500
Peak current I_{LPEAK} [mA], 10 ms, DIP/SMD			4000
On-state resistance R_{ON} [Ω], $I_F=10\text{mA}$, $I_L=1\text{A}$, 10 ms		0.1	0.2
Off-state leak. curr. I_{Lx} [μA], $I_F=0\text{mA}$, $V_F=50\text{V}$			1
Turn-on time T_{ON} [ms], $I_F=10\text{mA}$, $I_L=1\text{A}$			5
Turn-off time T_{OFF} [ms], $I_F=10\text{mA}$, $I_L=1\text{A}$		0.05	2
INPUT/OUTPUT			
I/O-capacitance $C_{i/o}$ [pF], $f=1\text{MHz}$		1	
I/O-isol. voltage $V_{i/o}(V_{AC})$, RH \leq 60%, 1min., DIP/SMD	2500		
I/O isol. resistance $R_{i/o}$ [G Ω], 500V _{DC} , delay 2 s	5		
Operating temperature T_{op} [°C]	-40		+85
Storage temperature T_{stg} [°C]	-40		+100

8 GB DDR3L SDRAM – AS4Cxxx SERIES

FEATURES

- » VDD = VDDQ = 1.35V (1.283–1.45V)
- » Backward compatible to VDD = VDDQ = 1.5V ±0.075V
- » Differential bidirectional data strobe
- » 8n-bit prefetch architecture
- » Differential clock inputs (CK, CK#)
- » 8 internal banks
- » Nominal and dynamic on-die termination (ODT) for data, strobe, and mask signals
- » Programmable CAS (READ) latency (CL)
- » Programmable posted CAS additive latency (AL)
- » Programmable CAS (WRITE) latency (CWL)
- » Fixed burst length (BL) of 8 and burst chop (BC) of 4 (via the mode register set [MRS])
- » Selectable BC4 or BL8 on-the-fly (OTF)
- » Self refresh mode
- » TC of 0°C to +95°C
 - 64ms, 8192-cycle refresh at 0°C to +85°C
 - 32ms at +85°C to +95°C
- » Self refresh temperature (SRT)
- » Automatic self refresh (ASR)
- » Write leveling
- » Multipurpose register
- » Output driver calibration

The **DDR3 SDRAM** is a high-speed, CMOS dynamic random access memory. It is internally configured as an 8-bank DRAM of 1.5V or less.

AS4C2GM4D3L – 256 Meg x 4 x 8 banks

AS4C1GM8D3L– 128 Meg x 8 x 8 banks

AS4C512M16D3L – 64 Meg x 16 x 8 banks

OPTIONS

- » Configuration
 - 2 Gig x 4 2G4
 - 1 Gig x 8 1G8
 - 512 Meg x 16 512M16
- » FBGA package (Pb-free) – ×4, ×8
 - 78-ball (9mm x 13.2mm) B
- » FBGA package (Pb-free) – ×16
 - 96-ball (9mm x 14mm) B
- » Timing – cycle time
 - 938 ps @ CL = 14 (DDR3-2133) -09
 - 1.07ns @ CL = 13 (DDR3-1866) -10
 - 1.25ns @ CL = 11 (DDR3-1600) -12
- » Operating temperature
 - Commercial (0°C ≤ TC ≤ +95°C) C
 - Industrial (–40°C ≤ TC ≤ +95°C) I

MARKING

ORDERING INFORMATION

PART NUMBER	CLOCK FREQUENCY	DATA RATE	OP. TEMPERATURE RANGE	PACKAGE	VOLTAGE SUPPLY
AS4C2GM4D3L-12BCN	800 MHz	1600	Commercial	78-ball (9mm×13.2mm) FBGA	1.35 V (1.283 V ... 1.45 V)
AS4C2GM4D3L-12BIN	800 MHz	1600	Industrial	78-ball (9mm×13.2mm) FBGA	1.35 V (1.283 V ... 1.45 V)
AS4C1GM8D3L-12BCN	800 MHz	1600	Commercial	78-ball (9mm×13.2mm) FBGA	1.35 V (1.283 V ... 1.45 V)
AS4C1GM8D3L-12BIN	800 MHz	1600	Industrial	78-ball (9mm×13.2mm) FBGA	1.35 V (1.283 V ... 1.45 V)
AS4C512GM16D3L-12BCN	800 MHz	1600	Commercial	96-ball (9mm×14mm) FBGA	1.35 V (1.283 V ... 1.45 V)
AS4C512GM16D3L-12BIN	800 MHz	1600	Industrial	96-ball (9mm×14mm) FBGA	1.35 V (1.283 V ... 1.45 V)

ANGULAR SENSOR FOR 3-PHASE BRUSHLESS MOTOR – MagAlpha MA300

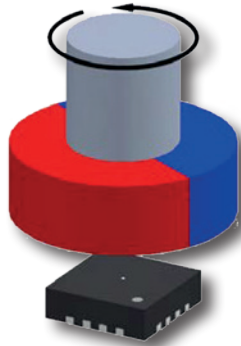

QFN16 3x3mm package

The **MagAlpha MA300** is a magnetic sensor designed to replace the 3 Hall switch solutions for 3 phases block commutation in brushless dc motors. The IC detects the absolute angular position of a permanent magnet, typically a diametrically magnetized cylinder attached to the rotor. The MagAlpha is an extremely fast acquisition and processing sensor, allowing accurate angle measurement at speeds from 0 to 120'000 RPM. Since the measurement is spatially confined, the user has flexibility in terms of magnet shapes and configurations. This can help relaxing mechanical tolerances and, in case the end of shaft position is not available, the MagAlpha MA300 can also operate away from the axis of rotation ("side-shaft" mounting).

FUNCTIONAL BLOCK DIAGRAM – MagAlpha MA300

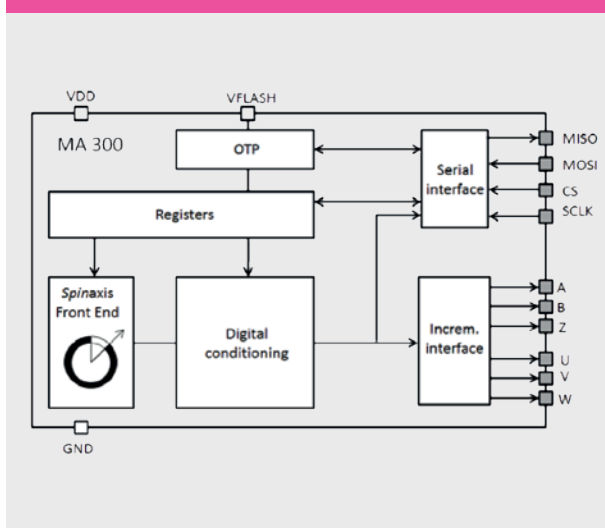

KEY FEATURES

- » U V W signals for block commutation
- » 11 bit resolution absolute angle encoder
- » 500 kHz refresh rate
- » Ultra low latency: 3 μ s
- » Serial interface for data readout and settings
- » 10 bit incremental output (A, B, Z)
- » Built-in linearization for side-shaft mounting
- » 7.5 mA supply current

OPERATING CONDITIONS

PARAMETER	RATING		
	min.	typ.	max.
Supply voltage V_{DD} [V]	3.0	3.3	3.6
Supply current I_{sup} [mA]	5.7	6.6	8.0
Operating temperature T_{op} [°C]	-40		+125
Applied magnetic field B [mT]	30	75	150

SENSOR OUTPUT SPECIFICATIONS

PARAMETER	RATING		
	min.	typ.	max.
ABSOLUTE OUTPUT - SERIAL			
Data output length [bit]	16		16
Refresh rate [kHz]	500	520	550
Latency [μ s]	2	3	4
Resolution (3σ noise level) [bit]	10.5	11.0	11.5
INCREMENTAL OUTPUT			
Resolution [edge/revol.]	1024		1024
Jitter [% of a period]		10	
Hysteresis [deg]			0.35

ANGULAR SENSOR FOR 3-PHASE BRUSHLESS MOTOR – MagAlpha MA300

PIN CONFIGURATION

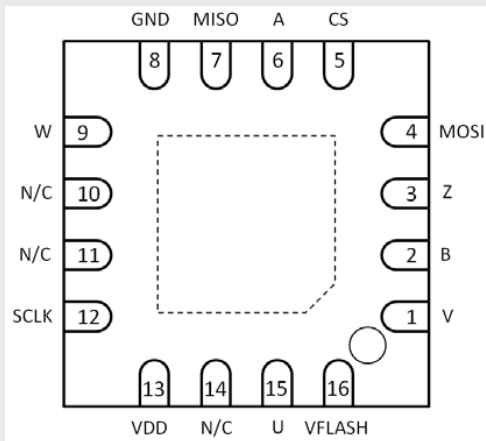

FIGURE 2 QFN16 Top view

TABLE 8 PIN FUNCTIONS

No	Name	Function
1	V	V (incremental output)
2	B	B (incremental output)
3	Z	Z (incremental output)
4	MOSI	Data in (serial)
5	CS	Chip Select (Serial)
6	A	A (incremental output)
7	MISO	Data out (serial)
8	GND	Ground
9	W	W (incremental output)
10	N/C	-
11	N/C	-
12	SCLK	Clock (serial)
13	VDD	3.3 V supply
14	N/C	-
15	U	U (incremental output)
16	VFLASH	3.6 V supply for OTP flashing

SENSOR – MAGNET MOUNTING

The sensitive volume of the MA300 is confined in a region less than 100 μm wide and consists of multiple integrated Hall devices. This volume is located, with a precision of 50 μm in the center of the QFN package, both horizontally and vertically. The sensor detects the angle of the magnetic field projected in a plane parallel to the package upper surface. It means that the only magnetic field that matters is the in-plane component (X and Y components) in the package middle point.

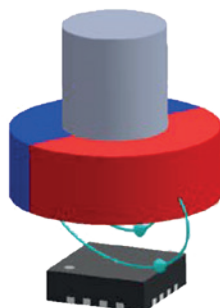

FIGURE 1 End-of-shaft mounting

This detection mode gives flexibility for the design of an angular encoder: all the sensor needs is that the magnetic vector lies essentially within the sensor plane and that its amplitude is comprised between 30 and 150 mT. Note that the MA300

does work with smaller than 30 mT fields, but the linearity and resolution performance may deviate from the specifications (table 2). The straightforward solution is to place the MA300 sensor on the rotation axis of a permanent magnet for instance a cylinder diametrically magnetized (fig. 1).

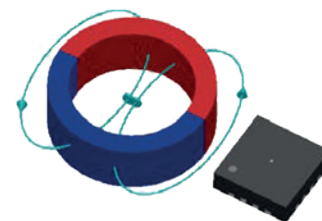

FIGURE 2 Side-shaft mounting

When the end-of-shaft position is not available the sensor can be positioned away from the rotation axis of a cylinder or ring magnet (fig. 2). In this case the magnetic field angle is not directly proportional to the mechanical angle anymore. The MA300 can be adjusted to compensate this effect and recover the linear relation between the mechanical angle and the sensor output. With multiple pole pairs, the MA300 will indicate multiple rotations for each mechanical turn.

ANGULAR SENSOR FOR 3-PHASE BRUSHLESS MOTOR – MagAlpha MA300

SENSOR FRONT-END

The magnetic field is detected with integrated Hall devices located in the package center. The particularity of this sensor is that the angle is measured using the spinaxis method which directly digitizes the direction of the field without any ATAN computation or any feedback loop based circuit (interpolators, etc.).

The spinaxis method is based on phase detection. It requires a sensitive circuitry generating a sinusoidal signal whose phase represents the angle of the magnetic field. The angle is then retrieved by a time-to-digital converter, which counts the time between the zero crossing of the sinusoidal signal and the edge of a constant waveform (Fig. 3). The digitized time is the front-end output.

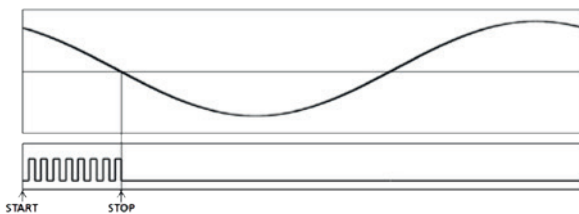

FIGURE 3 Phase detection method. Top: sine waveform. Bottom: clock of time-to-digital

Looking further down the treatment chain, it is crucial that the signal treatment does not add unwanted phase shifts. For this purpose the MagAlpha incorporates an architecture where these shifts are automatically compensated, resulting in the stability displayed in table 2. In short, the front-end delivers in a straightforward and open loop manner a digital number proportional to the angle of the magnetic field at the rate of 500 kHz.

INCREMENTAL – ABZ

With the ABZ output the MA300 emulates a 10-bit incremental encoder, such as an optical encoder, providing logic pulses in quadrature (fig. 4). Compared to A, the signal B is shifted by a quarter of pulse period. Over one revolution the A signal pulses 256 times. It makes 1024 edges per revolution. The signal Z ("Zero" or "Index") raises only once per turn, at the zero angle position.

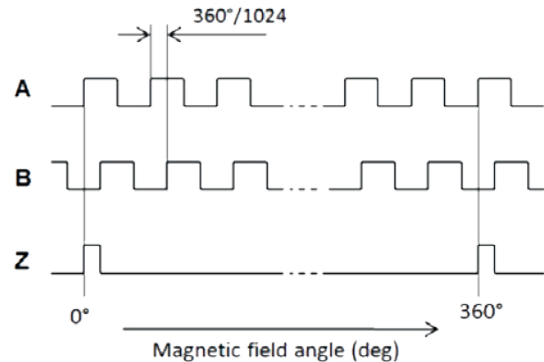

FIGURE 4 ABZ output during rotation

BLOCK COMMUTATION – UVW

The UVW output emulates the three Hall switches usually used for the block commutation of 3-phases electric motor. The three logic signals have a duty cycle of 1/2 and are shifted by 60 deg relative to each other (see fig. 5).

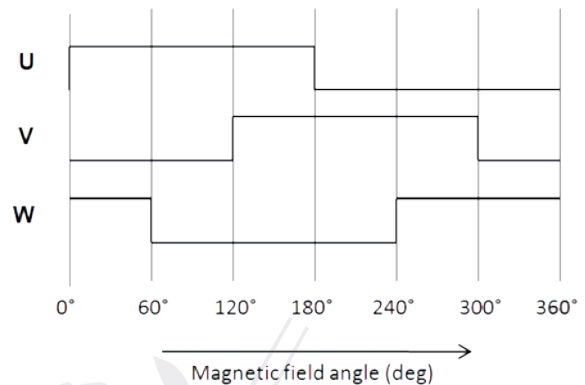

FIGURE 5 UVW output during rotation

EMBEDDED FINGERPRINT MODULE / GTM-5110C SERIES



TrueSecure™ 3D

FEATURES

- » Single chip fingerprint recognition module
- » Complete integrated algorithms for learn, login and erase functions
- » Advanced optical technology
- » High accuracy and high recognition speed
- » Ultra-thin optical sensor
- » 1:1 verification and 1:N identification
- » Downloadable sensor fingerprint image
- » Fingerprint templates can be read/written to module
- » UART communication protocol for interfacing to external master MCU
- » Easy fingerprint recognition product integration

APPLICATIONS

- » Notebook computer login
- » Household security products
- » Vehicle entry systems
- » Biometric identification products

Fingerprint recognition technology provides a secure and accurate means of biometric identification. This range of device offers users a quick and easy implementation method for biometric fingerprint recognition. The integration of an optical fingerprint sensor, Holtek 32-bit ARM core microcontroller and fully programmed algorithm into a single module together combine to form complete fingerprint recognition module. A number of fingerprint images or templates are stored within the device's internal Flash Memory and therefore retain storage when power is removed. The storage capacity varies according to the module type selected. With easy commands such as learn, login and erase, this range of device offers a convenient and easy-to-use solution for users wishing to implement fingerprint biometric security into their products.

BLOCKSCHALTBIELD

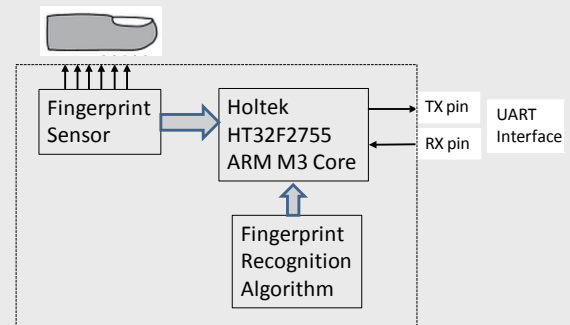

Vereinfachte Darstellung des Funktionsprinzips

SELECTION TABLE

PART NO.	EFFECTIVE AREA [mm ²]	RESOLUTION [dpi]	IMAGE PIXELS	NO. OF FINGERPRINTS	ROTATION [deg.]	TEMPLATE BYTE SIZE	COMPARE TIME [s]	DIMENSION W×D×H [mm ³]
GTM-5110C2	14×12.5	450	240×216	20	360	506	1.5	17×37.0×7.74
GTM-5110C21	14×12.5	450	240×216	20	360	506	1.5	21×36.1×7.74
GTM-5110C3	14×12.5	450	258×202	200	360	498	1.0	17×37.0×7.74
GTM-5110C31	14×12.5	450	258×202	200	360	498	1.0	21×36.1×7.74
GTM-5110C5	14×12.5	450	258×202	2000	360	498	1.5	17×37.0×7.74
GTM-5110C51	14×12.5	450	258×202	2000	360	498	1.5	21×36.1×7.74

The range of devices shown in the selection table are similar in function, but differ mainly in their fingerprint storage capacity, mechanical construction, pixel count, rotation range etc.

CUSTOM SEMITEC THERMISTORS: AUTOMOTIVE APPLICATIONS

FEATURES

- » Customized temperature sensors designed according to individual customer's and application requirements
- » Leading supplier for HV/EV application in Japan with >80% market share
- » Variety of metal and plastic housings and tubings designed for specific applications
- » Wide range of Resistance/Temperature characteristics

APPLICATIONS

- » Engine management systems e.g. oil, fuel and coolant temperature
- » Exhaust gas and EGR temperature
- » Hybrid & electric vehicles e.g. temperature sensors for battery packs (Li-Ion, Ni-MH), eWheel drive, eMotor, control unit
- » DC/DC converter / inverter
- » Climate control units

CUSTOM SEMITEC THERMISTORS –AUTOMOTIVE APPLICATIONS

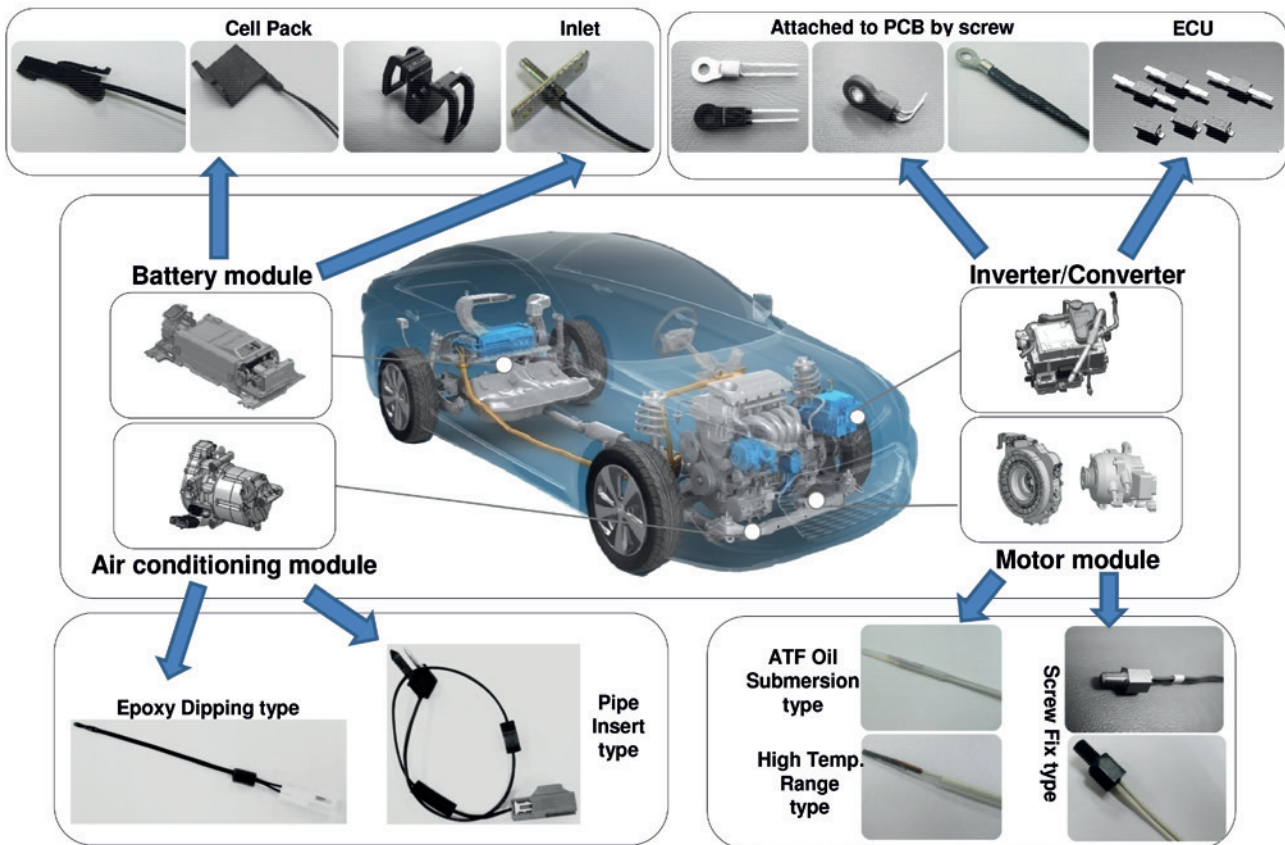

new

Contact for information: Mr. Graf · Tel. +49(0)7452-6007-941 · e-mail: o.graf@endrich.com

HEADQUARTERS

ENDRICH Bauelemente Vertriebs GmbH · P.O.Box 1251 · D-72192 Nagold
 T +49 (0) 7452 6007-0 · F +49 (0) 7452 6007-70
 endrich@endrich.com · www.endrich.com

SALES OFFICES IN EUROPE

France:
 Angers: T +33/2 41 80 33 54 · v.rousseau@endrich.com

Austria & Slovenia
 Vienna: T +43/1 66 52 52 521 · a.schwaha@endrich.com



Hungary:
 Budapest: T +361 / 2 97 41 91 · z.kiss@endrich.com

Bulgaria:
 Sofia: T +359/2 874 30 49 · bulgaria@endrich.com

Switzerland – Novitronic:
 Zurich: T +41/44 306 91 91 · info@novitronic.ch

Spain:
 Barcelona: T +34/93 217 31 44 · spain@endrich.com