

# endrich news

www.endrich.com

## ENDRICH GROUP GOES SOCIAL MEDIA!

HAVE A  
LOOK

Follow us  
on LinkedIn!

Endrich Group

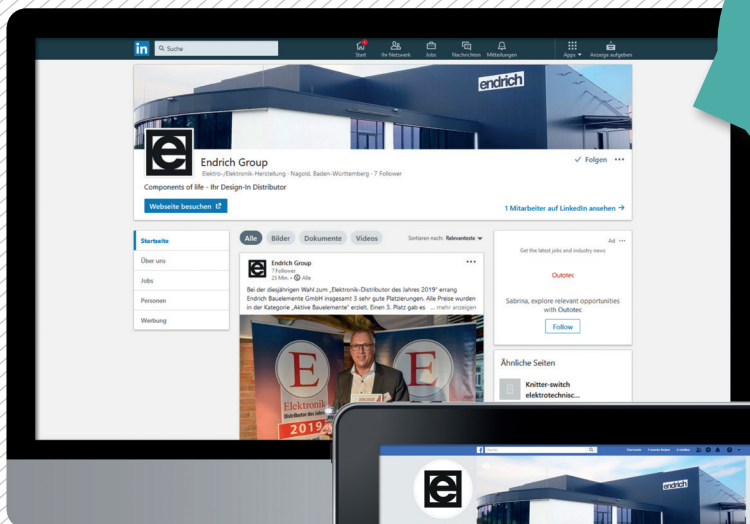

Follow us  
on Facebook!

Endrich Group

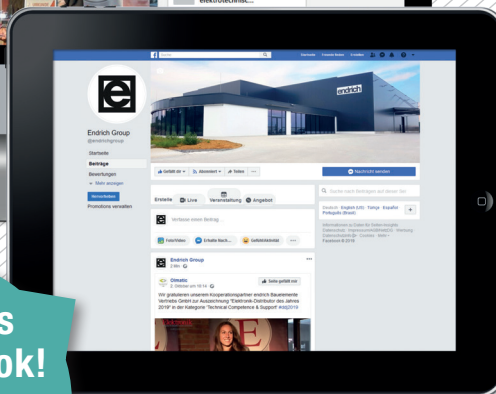

HAVE A  
LOOK

## GD32VF103 RISC-V MAINSTREAM PORTFOLIOS

GigaDevice Semiconductor, officially launches the world's first open source RISC-V based GD32V series 32-bit general-purpose MCU products. GigaDevice provides a complete tool chain support from MCU chips to software libraries and development boards; therefore, creating a strong RISC-V development ecosystem.

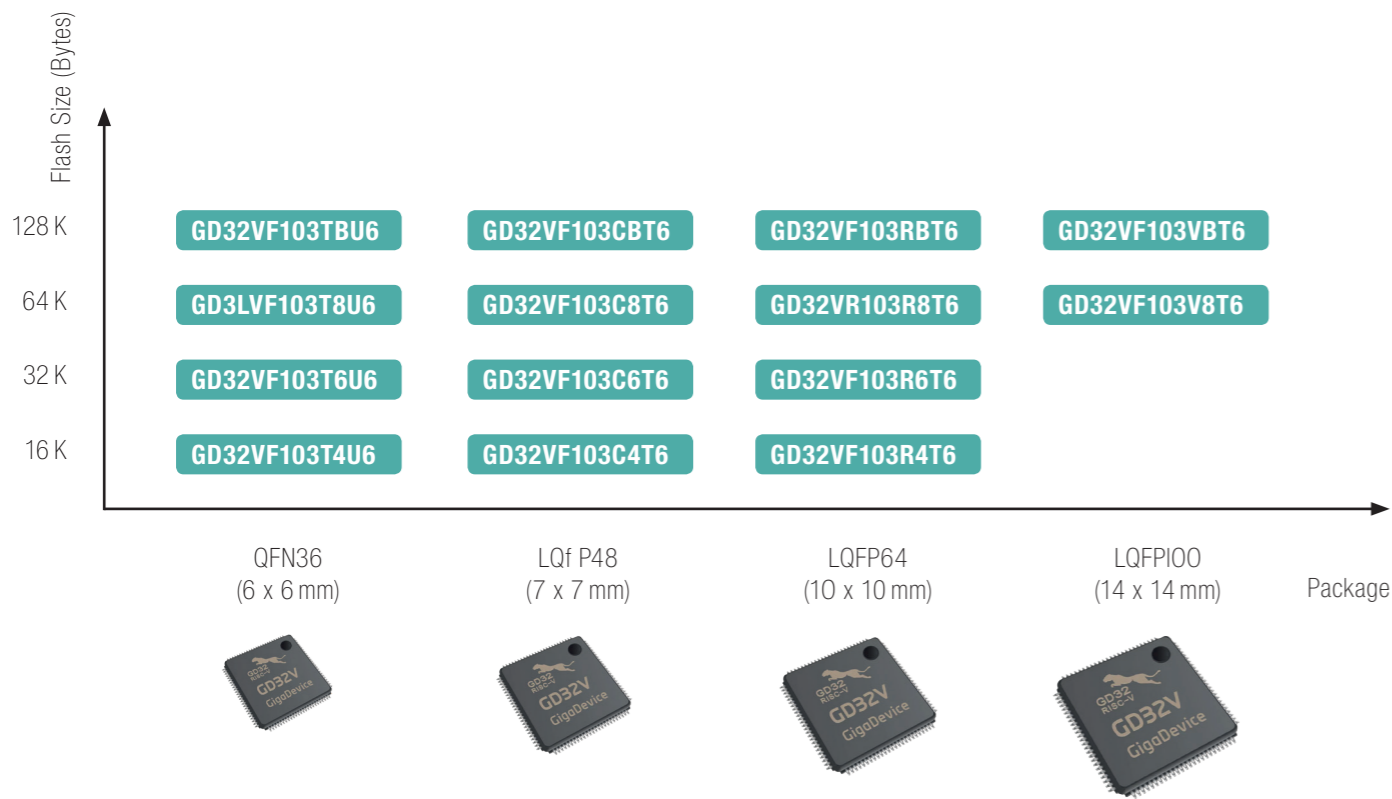

- GD32VF103 RISC-V bumblebee core mainstream line
- Max  $F_{CPU}$  108 MHz, 16 K – 128 K flash, 8 K – 32 K SRAM
- 40 °C to +85 °C industrial level operating temperature
- 2.6 – 3.6 V supply; 5 V tolerance I/O s; all support USB OTG & CAN 2.0B
- Series pin to pin compatible and flexible S/W compatible

## NJW1280 HIGH CAPACITANCE PIEZO-SOUNDER DRIVER WITH CHARGE PUMP

The NJW1280 is a switching driver with charge pump for high capacitance piezo-sounder. It can drive outputs up to 30 VPP from 5 V supply. Because the NJW1280 has shutdown function, it is suitable for battery application.

### FEATURES

- Operating voltage: +2.0 V to +5.5 V
- Consumption current (active):  $I_{DD11} = 3.5 \text{ mA typ. (VDD} = 3 \text{ V, FIN} = 4 \text{ kHz)}$
- Consumption current (shutdown):  $I_{SD1} = 0.5 \mu\text{A max. (VDD} = 3 \text{ V, IN} = 0 \text{ V)}$
- High capacitance driving: 30 nF typ.
- Differential output: 30 VPP max. (VDD = 5 V)
- Charge pump circuit (3 times)
- Input signal detector & auto shutdown control
- Operating temperature: -40 °C to +105 °C
- Bi-CMOS technology
- Package outline: EQFN16-G2, MSOP10 (TVSP10)

### APPLICATIONS

- Fire alarm
- Smoke detector
- Security alarm

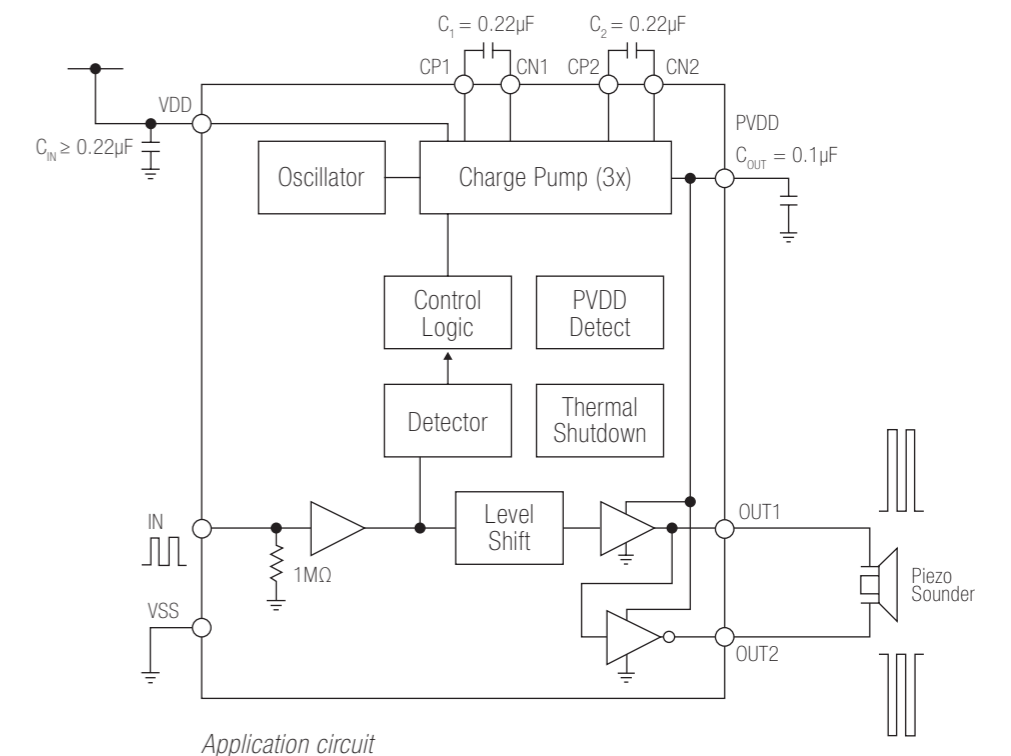

HAVE A LOOK

HAVE A LOOK

Meeting customer needs with extensive features. Offering suitable switch features such as operation feeling and reliability for our customers. Panasonic switch products have been adopted into various field applications.

**Variations (Tactile SW, Detector SW)**

To satisfy different design needs, many variations are offered such as top push operation, side push operation, vertical and horizontal direction detection.

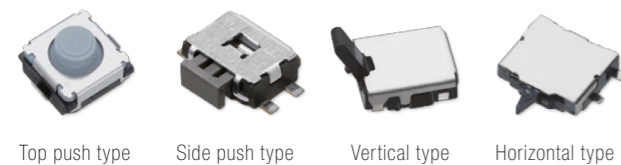

**Reliability (Tactile SW, Detector SW, Push SW)**

In order to raise reliability of customer's product, Panasonic switches make progress on operating life, water-proof and dust-proof property (IP67), anti-flux characteristics, contact reliability and shock resistance.

IP67: Protected from dust and capable of withstanding water immersion between 15 cm and 1 meter for 30 minutes (LTSW meets IP67).

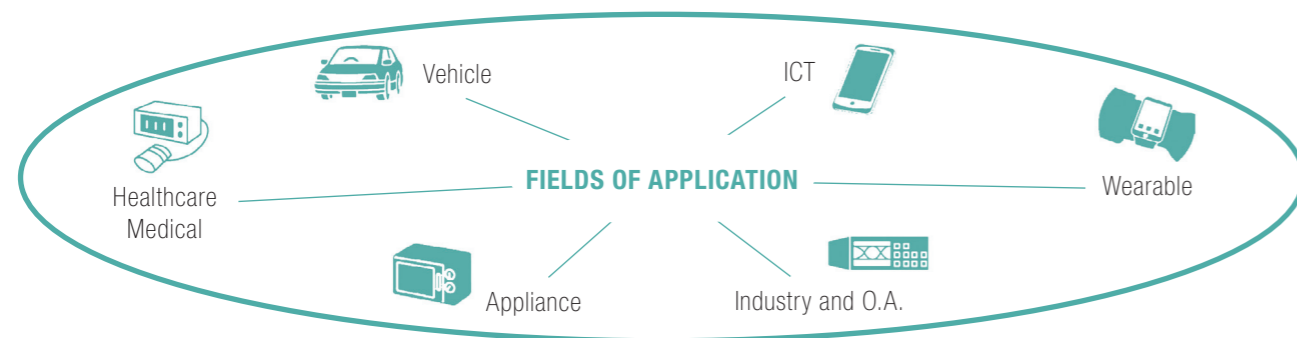
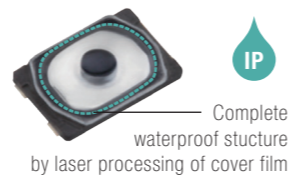

**Operation feeling (Tactile SW, Push SW)**

Operation feeling is one of the key feature of switches. The large selection of operation feeling and travel meet customer requests.

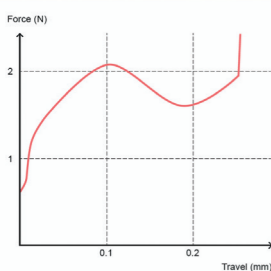

Feeling curve – Push switch

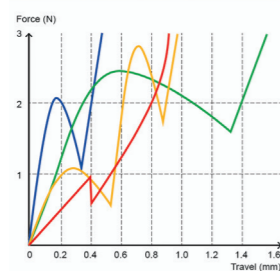

Feeling curve – Tactile switch

**Customization (Tactile SW)**

All tactile SW parts are designed and produced by Panasonic's own factory so that they are able to offer customization of click feeling and provide quick customer services.

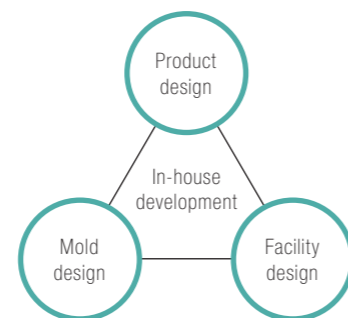

The PAN1740A is a BT5.0 up-grade version of the PAN1740. It features a reduced boot time and supports up to 8 connections. This ensures greater flexibility in the development of new applications.

A radio transceiver and a baseband processor for Bluetooth® 5.0 low energy are integrated. The PAN1740A has a build-in dedicated hardware for link layer implementation of Bluetooth® low energy and interface controllers for advanced connectivity features.

for Remote Control Units (RCU) that support voice commands as well as motion or gesture recognition. The integrated Audio Unit (AU) provides a simple interface for MEMS microphones via PDM, external codecs via PCM/I2S and a sample rate converter unit. The transceiver is directly connected to the antenna and fully complies with the Bluetooth® 5.0 standard.

The module is suitable for hosted systems as a data pump, but also as an independent application processor. It is optimized

**FEATURES**

- Complies to the Bluetooth® 5 core specification
- Pre-programmed BT/MAC address
- Includes 16 MHz and 32.768 kHz quartz, calibrated up to 1 ppm
- Single mode Bluetooth® 5.0 System-on-Chip DA14585
- Programmable ARM CORTEX M0 CPU
- Autonomous independent BTLE operation
- Bluetooth® v5.0 embedded GATT – Power-saving single mode
- Small 9.0 x 9.5 x 1.8 mm SMD package with antenna
- Peak power consumption 4.9 mA Rx and Tx
- Few µA in power save mode
- Integrated shielding against electromagnetic interference
- No external components required
- Operating temperature range -40 °C to +85 °C
- Integrated one-time-programmable memory 64 kB
- BT LE firmware profile support:
  - L2CAP service layer protocols, Security Manager (SM)
  - Attribute Protocol (ATT)
  - Generic Attribute Profiles (GATT)
  - Generic Access Profile (GAP)
  - All profiles published by the Bluetooth® SIG
  - Further user-defined profiles

The predecessor PAN1740 has the same form factor and is compatible with the SDK.

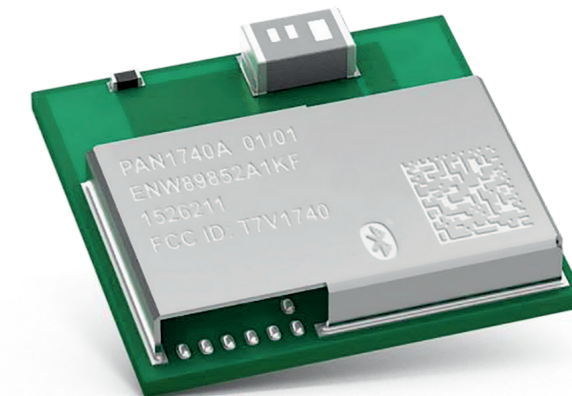

## SENSITIVE & POWERSAVING MAGNETIC SENSORS

Magnetic sensors based on the Hall effect have been known for a long time and have found their way into various industries. Meanwhile Tunnel Magneto-Resistance (TMR) represents the most advanced magnetic technology which is already proven in hard disk drives and now available for magnetic sensors as well.

These sensors based on the TMR effect belong to the family of magneto-resistive sensors, which is completed by the AMR and GMR sensors. TMR sensors are characterized by a multilayer system whose total electrical resistance perpendicular to the stack layers can be influenced by external magnetic fields. Extremely thin insulating layers in the layer system contribute to the high sensitivity and the low power consumption of the TMR sensors, making them the most promising member of the magneto-resistive family.

Crocus Technology has specialized in the development and manufacture of such TMR sensors and has introduced a new family to the market.

### PRODUCT DESCRIPTION & BENEFITS

The new CT81xx series from Crocus Technology is a product family of omnipolar, bipolar, and unipolar Tunnel Magneto-Resistance (TMR) digital and analog latches that are designed for industrial and consumer applications. It is based on Crocus Technology's patented Magnetic Logic Unit™ (MLUTM) technology with integrated CMOS process to provide a monolithic solution for superior sensing performance.

This product family has ultralow power consumption as low as 110 nA which is ideal for battery-operated products where minimal current consumption is required.

It supports magnetic fields down to 0.9 mT for applications where a large air gap is required. In addition, smaller magnets or lower grade magnetic materials can be applied reducing the magnet costs as well as providing a cheaper and smaller size solution.

With a wide operating voltage range from 1.7 V to 5.4 V, the CT81xx series is able to maintain all kind of applications for portable, mobile, and wearable consumer electronics that are powered by single coin cell batteries or Li-Ion batteries. Moreover, it allows to use common 5V power supplies in industrial and white good appliances without any need for an additional voltage regulator.

### FEATURES

- High sensitivity:  $B_{OP}/B_{RP}$  down to  $\pm 0.9$  mT /  $\pm 0.5$  mT
- Magnetic polarities supported:
  - Omnipolar
  - Unipolar
  - Bipolar
- Ultra-low current consumption: down to 110 nA @ 1.8 V
- Supply voltage range: 1.7 V to 5.4 V
- Outputs:
  - Digital CMOS: push-pull or open drain
  - Analog
- Under-Voltage LockOut (UVLO)
- Wide operating temperature ranges:
  - Industrial: -40 °C to +85 °C
  - Extended industrial: -40 °C to +125 °C
- Resistant to mechanical stress
- Industry standard packages (RoHS & REACH compliant):
  - 3-Lead SOT23
  - 3-Lead TO-92S
- Low profile and small form factor package:
  - 4-lead LGA, 1.50 × 1.50 × 0.45 mm

## SENSITIVE & POWERSAVING MAGNETIC SENSORS

The CT81xx series provides a stable and predictable magnetic performance over temperature. Hence no circuitry or algorithm for temperature compensation is required.

Industry standard packages 3-lead SOT23 and 3-lead TO-92S support high volume manufacturing for industrial markets. For applications that require a very small form factor and low profile, the CT81xx is assembled in a compact 4-lead LGA package. These robust and rugged packages ensure longer

operating lifetimes without any failures due to fatigue compared to Reed switches.

Finally, CT81xx TMR sensors can successfully replace Reed, Hall, AMR, and GMR sensors in many applications while providing a future-proof technology upgrade including all benefits mentioned above.



MARKETS	END PRODUCTS	APPLICATIONS
Industrial automation	Brushless DC motors	Speed / rotation sensing Angular / rotor position Motor control
	Positioning & proximity detection	Reed switch replacement
	Predictive maintenance	Wear monitoring
Industrial storage	Fluid level sensors	Switch to detect series of fluid levels
Industrial / energy	Flow meters	Speed / rotation sensing
Enterprise	Smart utility meters	Tamper-proofing Reader activation
Security	Smart locks Window / door sensors	Open / close position
White goods	Smart appliances <ul style="list-style-type: none"> <li>▪ Refrigerators</li> <li>▪ Clothes washer / dryer</li> <li>▪ Freezers</li> <li>▪ Dishwashers</li> </ul> Small appliances	Door / lid open / close Liquid level sensing Fluid flow sensing Motor control Speed / rotation sensing Power switch
Consumer	eBikes	Power switch Speed / rotation sensing
Medical	Drug dispensing wearables	Fluid level of medication Power-on device

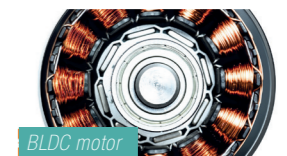
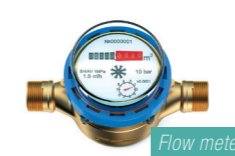

Further new TMR products from Crocus Technology, such as 1D linear sensors, 2D angular sensors and current sensors, will be published in Endrich News beginning of 2020.

## COMPETITIVE – HIGH CURRENT MOLDING POWER CHOKES

**HAVE A  
LOOK**

Prosperity Dielectrics Co., Ltd. (PDC) was founded in 1990 as the 1st local manufacturer and exporter in Taiwan for ceramic dielectric powders and multiple-layer ceramic chip capacitors (MLCCs). Today PDC is a highly capable manufacturer of specialty resistors, capacitors and coils. Recently PDC has invested some capital to make the manufacturing process of their high current molding choke line „MCS“ highly efficient. This improvement results in an excellent quality, stable supply and very competitive prices.

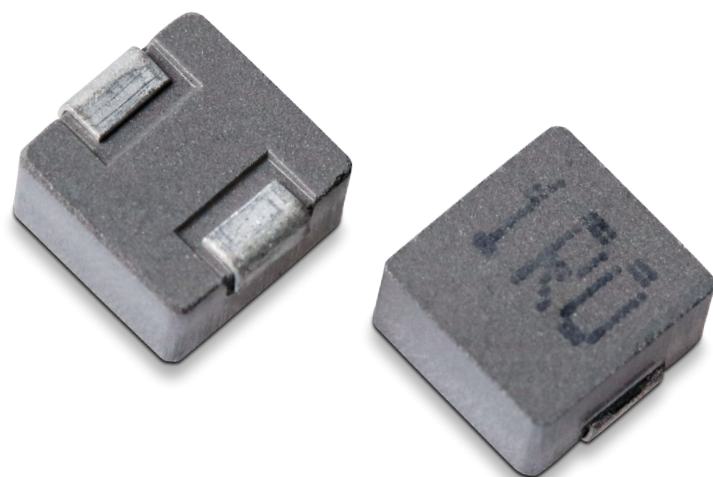

### FEATURES

- Higher current compared with ferrite chokes
- Reduced DCR down to a few mOhms
- Soft saturation effect
- Monolithic structure
- Free of cracks

### APPLICATIONS

- DC/DC converter
- POL converter
- Communication, IT, embedded and peripheral
- Consumer, white goods
- Industrial applications

SERIES	SIZE	INDUCTANCE RANGE	RCD	IDC	Isat A
MCS0420	4.45 x 4.0 x 2.0 mm	0.10 ~ 10.0 µH	3.5 ~ 256 mOhm	12.0 ~ 1.2 A	22.0 ~ 2.2 A
MCS0530	5.4 x 5.2 x 3.0 mm	0.20 ~ 10.0 µH	3.5 ~ 110 mOhm	18.0 ~ 2.5 A	14.5 ~ 3.5 A
MCS0630	7.3 x 6.6 x 3.0 mm	0.15 ~ 15.0 µH	1.9 ~ 110 mOhm	26.0 ~ 3.5 A	52.0 ~ 3.0 A
MCS1040	11.15 x 10.0 x 4.0 mm	0.22 ~ 68.0 µH	1.0 ~ 200 mOhm	35.0 ~ 2.5 A	50.0 ~ 3.0 A

Samples available, please contact us for details.

Contact for information: Mr. Jung · phone: +49(0)7452-6007-26 · e-mail: t.jung@endrich.com

### HEADQUARTERS

Endrich Bauelemente Vertriebs GmbH  
P.O.Box 1251 · 72192 Nagold, Germany  
T +49 (0) 7452 6007-0  
F +49 (0) 7452 6007-70  
E [endrich@endrich.com](mailto:endrich@endrich.com)  
[www.endrich.com](http://www.endrich.com)

### SALES OFFICES IN EUROPE

**France**  
Paris:  
T +33/186653215  
[france@endrich.com](mailto:france@endrich.com)

Lyon:  
T +33/186653215  
[france2@endrich.com](mailto:france2@endrich.com)

**Spain**  
Barcelona:  
T +34/93 217 31 44  
[spain@endrich.com](mailto:spain@endrich.com)

**Bulgaria**  
Sofia:  
[bulgaria@endrich.com](mailto:bulgaria@endrich.com)

**Austria & Slovenia**  
Brunn am Gebirge:  
T +43/1 665 25 25  
[austria@endrich.com](mailto:austria@endrich.com)

**Romania**  
Timisoara:  
[romania@endrich.com](mailto:romania@endrich.com)

**Hungary**  
Budapest:  
T +361/2 97 41 91  
[hungary@endrich.com](mailto:hungary@endrich.com)

**Switzerland – Novitronic**  
Zurich:  
T +41/44 306 91 91  
[info@novitronic.ch](mailto:info@novitronic.ch)